

UDK 005.8

¹**Oleksii E. Kolesnikov**, Candidate of Technical Sciences, Associate Professor of the Department of Systems Management Life Safety, E-mail: kae@opu.ua, Scopus ID: 57192559239,

ORCID: <http://orcid.org/0000-0003-2366-1920>

²**Dmytro V. Lukianov**, Candidate of Technical Sciences, Associate Professor of the Department of General and Clinical Psychology, E-mail: lukianov@bsu.by, Scopus ID: 57192572835,

ORCID: <http://orcid.org/0000-0001-8305-2217>

³**Olha I. Sherstyuk**, Candidate of Technical Sciences, Associate Professor of the Department of Management and Marketing, E-mail: sherstyuk1990@bk.ru, ORCID: <http://orcid.org/0000-0002-0482-2656>

⁴**Kateryna V. Kolesnikova**, Doctor of Technical Sciences, Professor of the Department of Technology Management, E-mail: amberk4@gmail.com, Scopus ID: 57188623059,

ORCID: <https://orcid.org/0000-0002-9160-5982>

¹Odessa National Polytechnic University, Avenue Shevchenko, 1, Odessa, Ukraine, 65044

²Belarusian State University, Nezavisimosti Avenue, 4, Minsk, Belarus, 220030

³Odessa National Maritime University, Mechnikov Street, 34, Odessa, Ukraine, 65029

⁴Taras Shevchenko National University of Kyiv, Volodymyrska Street, 60, Kyiv, Ukraine, 01033

PROJECT MANAGER JOB DESCRIPTION AS ONE OF PROJECT MANAGEMENT KEY SUCCESS FACTORS

Annotation. *The article discusses the practical aspects of profiling knowledge in project management, taking into account competence and experience for various categories of professionals involved in project management. Very often, project managers are forced to not only manage the project, but also train the project team members or help them develop their best skills to achieve the project goal. It is shown that success of project activities of organizations substantially depends on the professional personnel training and the proper formation of project participants' job descriptions. In addition to the formal responsibilities outlined in the basic project management methodologies the project manager plays an important role in the interaction between the project and the business area. Market pressure on project activities is associated with a rapid reduction in the life cycles of technologies and products, which significantly increases the responsibility of project managers for the ultimate fate of their project outputs. The employees' knowledge, skills and competencies are the basis for the development and improvement of any organization. In this case, more and more situations arise when, under extremely short deadlines, it is necessary to make a decision on the project team formation and on the selection of the project manager. When executing projects, there is always a need to coordinate the work of managers, staff and project team. To do this, organizations develop the rules of interaction and managers' responsibilities, as well as determine the managers' responsibility for various types of work. The responsibilities of managers are fixed in the job descriptions, which serve as the basis for the formation of responsibility matrices. At the same time, the fulfillment of the type of work specified in the instruction must be supported by the performer's certain competence. A general concept of forming job descriptions is proposed. Each instruction point is formed at the intersection of three coordinates: the performer, the work and the competence. A Markov model for changing the project manager's states has been developed, which describes the system using homogeneous Markov chains with discrete states and time. Discrete states form a specific structure of communications and interaction of project processes, which take into account the system topology and contextual features of the processes of project activities.*

Keywords: *project management, project team, competence, responsibility matrix, Markov's chain, manager's job model*

Introduction. Today, when product life cycles are rapidly declining, some outputs are rapidly replacing each other, outputs of leading companies, as soon as such an opportunity arises, are copied in a variety of imitation products of a multitude of second-line manufacturers the questions of evaluating the success of projects are perhaps the least developed and at the same time the most important in the field of project management.

One of the tools for successful project activities is the high-quality integration of management functions such as monitoring, managing and creating an effective project team.

A project manager is a person endowed with the authority and responsibility for daily project management and he is a person who is responsible for the successful implementation of the project.

© Kolesnikov O., Lukianov D., Sherstyuk O.,

Kolesnikova K., 2019

In addition, the project manager is leads the project team and manages its work. Every day, project managers are provided with information about the project resources, about all the work and people who are involved in a particular project. Very often, project managers are forced to not only manage the project, but also train the project team members or help them develop their best skills to achieve the project goal.

In addition to the formal responsibilities outlined in the basic project management methodologies, such as PMI PMBoK, PRINCE2, IPMA ICB, the project manager plays an important role in the interaction between the project and the business area. It is important to constantly maintain a high level of information and maintain the ability to quickly respond to changes in the business sector to provide new opportunities in project activities. Another important success factor is the willingness

This is an open access article under the CC BY license (<http://creativecommons.org/licenses/by/4.0/deed.uk>)

of the business to use new opportunities, the so-called key success factors that are formed in the process of project management.

In this regard, the responsibility of project managers of leading organizations for the ultimate fate of their project outputs is growing. In this case, an increasingly frequent situation arises when it is necessary to make a decision on the formation of a project team, and also on the choice of the project manager himself, who will have to lead the project management team and bring the project to success expected by the customer from the executing company within extremely short deadlines. And, on top of that, the management of the company-customer, incl. and in the case of an internal company project, need to make such decisions quickly.

Literature review

Theoretically, such decisions are made primarily by senior managers, in project management, based on the IPMA ICB standard; these should be category A and B managers. But, due to the fact that formally certified managers of this level in the entire post-Soviet space are no more than a thousand, and there are a lot of people who actually perform the work of project managers of this level (much more than the number of certified specialists), then we can speak about top managers of companies dealing with development projects of their companies, and with projects aimed at satisfying the external customer, as well as with projects to create new products / services and bring them to the market. At the same time, it is often possible to see a situation where the preliminary selection of candidates is delegated to an external recruiting company, often specializing in banal buying up of managers from one place to another, shuffling a relatively constant “deck” of personal cards of “potential customers”. More serious companies are able to really speak the same language with “human resources” of top management, using more sophisticated methods.

Both those and others for this are most often staffed with professional psychologists, but a much smaller number of such organizations have at their disposal former or current top managers who directly perform the functions of such a selection. In this regard, the standard set of actions during the competition often also includes test suites, aimed primarily at slices of measuring intellectual abilities. Formal intelligence is most often measured – what is meant by IQ. Despite the fact that now the types of intelligence are considered much more - from emotional to tactile, they are extremely rare (other types of intelligence) are subject to conscious evaluation in order to improve the performance of

recruitment work. Moreover, the higher the company's requests to the applicant from the point of view of the potential place in the management hierarchy are, the less the applicant's desire to fill in all kinds of forms, tests and questionnaires is. It would be convenient to shift some of this work to relevant professional associations that certify specialists and managers in narrow fields of activity. Such work is carried out by international associations IPMA, PMI and other professional certification centers. From the beginning of the twenty-first century, those competencies that had not previously been considered in technical activity, behavioral competences, were in the sphere of their interests. Nevertheless, this work is still only at the initial stage today, in particular, due to the ambiguity of its support mechanisms and the degree of usefulness of this kind of information, obtained, as a rule, as a result of passing certain tests by candidates.

On the other hand, nevertheless, some tools and methods have shown themselves to be positive for quite a long time and have confirmed that they can and should be used both when choosing a project manager and when forming a project team. This is the well-known Belbin test [1], which can be found in more detail in publications published in recent years [2; 3]. Taking into account the history of the test and the process of its development for teams of managers, in situations where these teams were temporary, which makes the results of research, even more relevant to the project, rather than operational management. The Belbin test and its modifications [4-5] should be used both during the initial selection of project team members, and when accompanying project teams and specific project managers, as a tool for rapid assessment in real time.

But apart from understanding what roles are in teams, it is important that the composition of the project team to be balanced by roles. Therefore, project team members are primarily interested in the “profile” of a successful project manager.

In the 4 – L – C IPMA model, this refers primarily to the C and B levels [6], in the PMI model to the PMP itself and to the PgMP certification program [7-8]. For several years of acquaintance with this test and its results, more than a hundred managers from various organizations, both participating in projects and employed only by management, have had the opportunity to analyze the test results of the same managers for some time. This allowed us to link the dynamics of change with the types of activities that project managers and project teams were engaged in. There was also an assumption that for successful project managers in profiles B and C in relation to IPMA certification

levels, it is possible to distinguish the corresponding profile according to the Belbin model. It was also interesting that the test results for the same manager subject to a change in his profile of activity / place in the company / project, change. Therefore, this methodology should be applied when moving from one position to another, as well as after a reference period to assess the success of the manager's adaptation to the occupied position. This feature was also noted by other researchers [11], but it was not always properly interpreted.

The approach to making decisions about taking places in the project team based on the assessment of competencies proposed by T. Fesenko is also of interest [12]. The method takes into account the additional requirements for each of the blocks of the traditional ICB IPMA model. Another example of the use in practice of approaches to the assessment of the competencies of managers' behavioral competence is used in the work of O. Radyuk [13]. In the works of Beloshchitsky A. definitions for the "project-vector" space are given, which can be applicable in the formation of job descriptions, if part of this space is considered as part of the competency requirements [14].

However, existing methods of competency analysis do not always ensure the requirements of practice for quality selection of project managers to be met due to the absence of models, methods and means of evaluating results. [15]. Solving problems that arise in the methodology of project-vector management of organizations depends on the level of competencies of project managers [16]. Creating models that reflect the structure and linkages of competencies for forming proactive learning management mechanisms based on them is possible using graph theory methods [17]. Models of competency structures will allow determining the influence of individual managers and project teams' competence level on the results of their implementation [18].

The purpose of the article. Trends in project management in the field of standardization demonstrate the increasing operationalization of project activity, highlighting the recurring elements of activities related to project management and project decision-making. This allows forming requirements for the work performed and specialists' job descriptions in project management [19-21]. Therefore, the purpose of this article is to develop a methodology for creating a project manager's job description based on the IPMA ICB competency standard [21].

Main part. The concept of forming the manager's job description. The practice of project management orients project managers to take into

account the differentiated requirements for the degree of proficiency in certain competencies for professionals involved in project management at different levels of the organization.

Project implementation is a movement in the project-vector space. The project-vector space of the organization does not contain a vacuum (void). Let us draw analogies with physical space. Usual measurements for us are height, width, length and time. The dimensions of the design vector space depend on the orientation of the project management system (which categories need to be managed) and these measurements will be proposed in the project-vector management methodology. But one dimension in the project activity coincides with one of the dimensions of the physical space, i.e. time.

The vertical labor division, i.e. separation of the coordination function from the direct execution of tasks is a condition necessary for the successful activity of the organization. As a result of the deliberate labor vertical division in the organization, a hierarchy of management levels is formed. The main characteristic of this hierarchy is the relationship based on the formal subordination of workers at each level. A person holding a top management position may have several middle managers subordinate to him from different functional areas. Several first-line managers, in turn, obey middle managers. As a result, hierarchical relationships permeate the entire organization, down to the level of ordinary staff.

The number of people accountable to one manager is called the span of control. This is a critical aspect of the organizational structure. If a lot of employees obey one manager, then the rate of control is large, which results in a flat organization structure. If the span of control is small, then the organization has a high structure. As a rule, large organizations with a flat structure have fewer levels of management than organizations of comparable size with a high structure.

The ideal span of control does not exist; this indicator is affected by many variables within the organization and in the external environment. Moreover, neither the span of control nor the height of the organizational structure is dependent on the size of the organization. For example, the goals and activities of the Roman Catholic Church and the Sears retailer are very different, but they are both famous for their huge span of control and a small number of management levels. The church, an organization with millions of members worldwide, has only four levels, and the standard army structure, which unites a hundred people and includes ten military ranks.

Organizational design is intended to create for any organization an executive mechanism, due to which it will exist and implement its strategy. As a result, the company receives an organizational structure, distribution of functions (top level) by subdivisions and a system of responsibility. A well-organized organizational structure is the basis, without which the effective activity of any organization is impossible. The project results on organizational development are recorded in the provisions on the organizational structure, departments and services. It is important that these data ultimately reach the specific contractor in the form of job descriptions, which determine the knowledge and level of qualification necessary for the execution of project works. These job descriptions can be provided not only in the form of paper documents, but also in the form of an electronic model that can be developed and improved by the organization itself.

The process of improving the management system is carried out in stages, with an assessment of the effectiveness of each stage and careful planning of changes. The implementation of this approach is possible only with the involvement of employees in the process, in accordance with the principles of ISO 9001.

When implementing projects, there is always a need for coordinating the work of managers. To do

this, the project organizations develop rules of interaction and responsibilities of managers, as well as determine the responsibility of managers for various types of work. The responsibilities of managers are fixed in the job descriptions, which serve as a basis for forming responsibility matrices for all organization processes. Thus, the instruction defines the list of duties, i.e. works b_j ($j = 1, 2, \dots, k$) of the performer a_i ($i = 1, 2, \dots, n$). At the same time, the implementation of the work type b_j defined in the instruction ($j = 1, 2, \dots, k$) must be supported by the presence of a certain competence s_{fv} ($f = 1, 2, 3$; $v = 1, 2, \dots, 20$ for $f = 1$; $v = 1, 2, \dots, 15$ for $f = 2$; $v = 1, 2, \dots, 11$ for $f = 3$):

$$I_j:R\{b_j \rightarrow a_i\} \leftrightarrow K:\{s_{fv} \rightarrow b_j\}, j = 1, 2, \dots, k,$$

where: I_j – duties by type of work R in the instruction, $j = 1, 2, \dots, k$; K – project management competencies.

According to the IPMA ICB standard, the project management knowledge area covers the following competencies: technical, behavioral and contextual. All elements of the set of competences have complex interrelations and in fact form the knowledge space of project management, which is the field of project managers' activity [22]. A total of 46 competencies are identified in the standard: 20 technical, 15 behavioral and 11 contextual (Table 1).

Table 1. Elements of competencies [22]

1. Technical competences	2. Behavioral competences	3. Contextual competences
1.01. The success of project management	2.01. Leadership	3.01. Project orientation
1.02. The stakeholders	2.02. Engagement and motivation	3.02. Programme orientation
1.03. Requirements and objectives of the project	2.03. Self-Control	3.03. Portfolio orientation
1.04. Risks and possibility of the project	2.04. Assertiveness	3.04. PPP implementation
1.05. Quality	2.05. Relaxation	3.05. Permanent organization
1.06. Project organization	2.06. Openness	3.06. Business
1.07. The teamwork	2.07. Creativity	3.07. Systems, products and technology
1.08. The solution of problems	2.08. Results orientation	3.08. Personnel management
1.09. The structure of the project	2.09. Efficiency	3.09. Health, safety, security and environment
1.10. Design and final product of the project	2.10. Consultation	3.10. Finance
1.11. Time and phase of the project	2.11. Negotiation	3.11. Legal
1.12. Resources of the project	2.12. Conflict and crisis	
1.13. Costs and finance of the project	2.13. Reliability	
1.14. Purchase and contracts of the project	2.14. Values appreciation	
1.15. Changes	2.15. Ethics	
1.16. Monitoring and reporting		
1.17. Information and documentation		
1.18. Communication		
1.19. Start of the project		
1.20. End of the project		

Fig. 1 shows the general concept of the formation of job descriptions. At the same time, to simplify the presentation, only technical competencies are considered.

Each instruction point is formed at the intersection of three coordinates: the performer, the work and the competence. This position is obvious and does not require proof, i.e. a competent manager with relevant training must perform certain work. This statement is followed by recommendations for forming the team and project staff. There are two possible options. As to the first option, the implementer is selected for a specific type of work; this is the best solution to a personnel problem if the implementer has the necessary competence. Otherwise, it is necessary to solve the task of selecting works that correspond to the competencies of the implementer. In this case, it is necessary to carry out the redistribution of duties, i.e. works with the involvement of a sometimes large enough number of performers.

Using the example of the best practice and the RACI methodology [17; 23], three levels of responsibility in the job instruction such as the implementer, the co-implementer and the informed are included. (Fig. 1).

The number of duties, i.e. works at each level of responsibility will be equal to seven taking into account the recommendations of George Miller's,

who summarized the data on the amount of a person's attention, linking them with the amount of short-term memory. The author showed that this volume is determined not by the number of words in the sentence, but by the number of objects, and is usually equal to 7 ± 2 for countable objects [24].

In recent years, the theory and practice of project management have been enriched by methods of quantitative assessment of the influence of organizational and production factors on the results of project activity. The most commonly used are mathematical methods that are based on operations research models, namely: correlation and regression analysis, mathematical modeling, peer-review and probabilistic methods. Mathematical models allow defining different project indicators. In this case, several different information and optimization models can be used to manage a particular project. The appearance and structure of the models are determined by the project management tasks and the availability of reliable information to obtain reliable solutions.

In the conditions of incomplete definition of project processes, it is convenient to use graphical probabilistic models, which are represented as graphs whose vertices represent random variables and edges show correlations between them, for estimating quantitative parameters of the project activity.

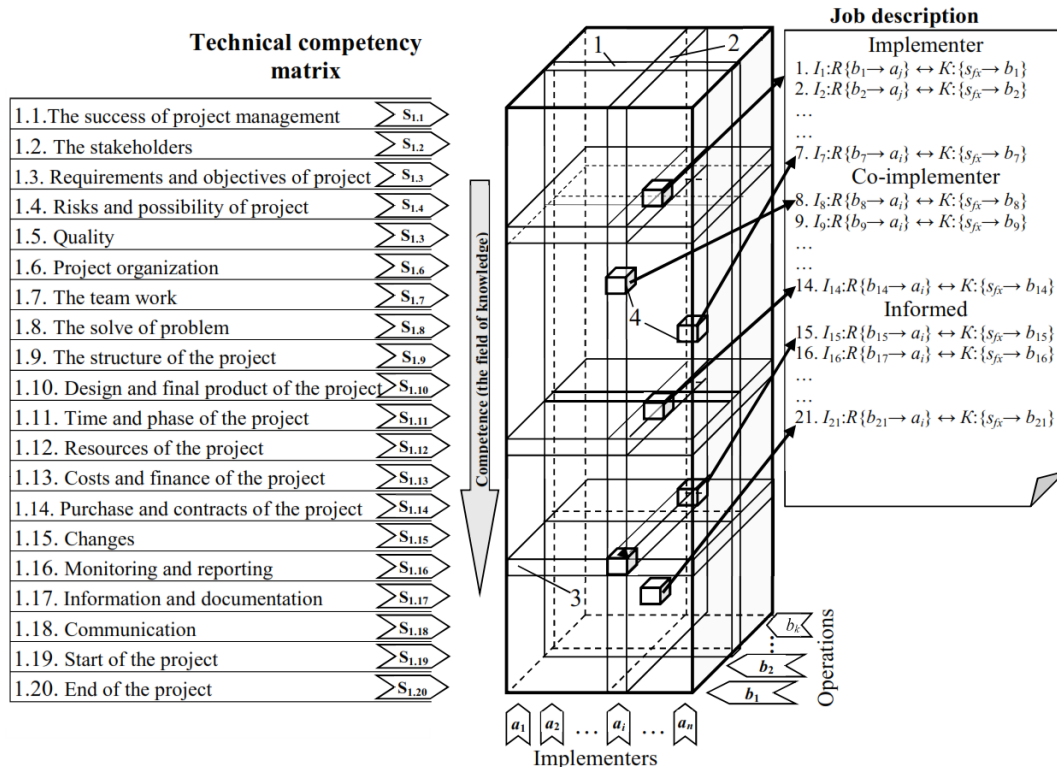

Fig. 1. The model of formation of instruction managers (based on technical skills):
 1, 2, 3 – the fields of knowledge on operations, implementers (doers) and competencies (space of Responsibility Matrix); 4 – competences of the implementer, which are works in project

Markov random processes are the basis of the general theory of random processes, as well as such important areas of application as diffusion processes, studies of operations, queuing systems etc. Due to the simplicity and clarity of the mathematical apparatus, the high reliability of the description of phenomenological properties and the accuracy of the obtained solutions, special attention was given to the Markov's chain by specialists engaged in the study of poorly structured organizational and technical and social project management systems [24-25].

The set of factors in weakly structured systems forms a complex web of connections between states that change over time depending on the structure of the system and the internal and external environment factors. The development of projects in such a multifactor system can often be imagined only in the form of quality models [26]. At the same time, the use of Markov chains allows

moving to quantitative estimates of the progress and results of projects [27-29].

When modeling complex project management systems, the key is to reflect the structure of the project process interaction with an oriented weighted graph, in which:

- the vertices correspond to the basic factors (states) of the project;
- direct relationships between states reflect the cause-and-effect chains, over which the influence of the certain factor on other factors is extended.

The structural and parametric similarity of the Markov chain and the activities of the project manager are given in Table. 2. The above similarity leads to the conclusion that the Markov chain is an acceptable model of the original.

Table 2. Analysis of model properties in the context of its “Markov behavior”

General properties	Markov chain (model)	Project manager (original)
Transitions from the present to future states	The probability of any state of the system in the future (for $t > t_0$) depends only on its current state and does not depend on when and how the system came into this state.	Project management: a random process, it is impossible to take into account the background of the transition of project managers to a new state; for project managers, in general, states can be distinguished
Compliance with steps	In a Markov chain with discrete time, the transition from the certain state to others is carried out according to the steps of the process, therefore, the step number acts as a discrete time: 0, 1, 2 ... k.	Transitions from a certain state during project management are carried out according to the process steps.
The presence of transition probabilities	A Markov chain with discrete states is shown as moving a point along the state graph randomly with leaping in other states. Moreover, transition probabilities depend only on the characteristics of each state.	The result of using the knowledge of the project team is shown in a change in the status of project managers. You can specify a list of transitions to other states in one step. Transition probabilities depend on system properties
Condition for probabilities of system states	The sum of the probabilities of all system states at each step is equal to one.	The states of project managers comprise a complete group of events; therefore, the sum of the probabilities of these states is equal to one.
Condition for probabilities of transitions to other states	The sum of the transition probabilities to other states for each state of the Markov chain is equal to one.	Transitions from any state to others constitute a complete group of events; therefore, the sum of the probabilities of these transitions is equal to one.
Topological similarity	Markov chains are shown by an oriented labeled graph, which indicates the possible transitions from each state to another in one step.	The states of the system are displayed in a graph, indicating the possible transitions from one state to another in one step.

To move to building a Markov model, we assume that the manager always does one work (sometimes performs an interruption to getting down to another work in accordance with his official duties, but still it is one work at each point of time). Each job is a state in which the manager is located. These states have the Markov property: the transition to other states does not depend on when and how the manager came to this state.

Based on the accepted assumptions, we go to the creation of a Markov model. Discrete states are known. It is necessary to construct a directed transition graph in one step from each state to another.

There are three options for solving this problem.

1. Accept that the manager from any state can move on to other jobs. In this case, the problem of identifying the model from real data arises. We carry out a photograph of the manager’s working day, determine the real probabilities of the states and, solving the inverse problem of a Markov chain, we calculate (find) the transition probabilities. Let us estimate the computational complexity of this problem: from each state for a complete graph we have 21 transition probabilities, 21 states, 212

variables. We have a 441×441 matrix. Therefore, at a minimum, it is necessary to have 441 measurements in the photo of the working day (if the system of equations is solved using the least squares method). And there is several times more data, if we use statistical methods.

2. Build transitions in accordance with the project implementation logic. The dimension of the problem will be much less. The definition of transition probabilities can be carried out according to the method presented in paragraph 1. Build transitions in accordance with the relationships that are determined by the matrix of competencies. Relationships are set. The solution is according to paragraph 1.

3. The analysis shows that the model of the system exists in two planes, in two realities. One plane displays the connections of competencies, and the second one displays the logic of the project operations (Fig. 2).

The Project Manager’s job description includes managing the arrangement of the Output in accordance with the manufacturing plan, setting the production of new Products in accordance with the innovation plan, shown in Fig. 3 in the form of a directed graph.

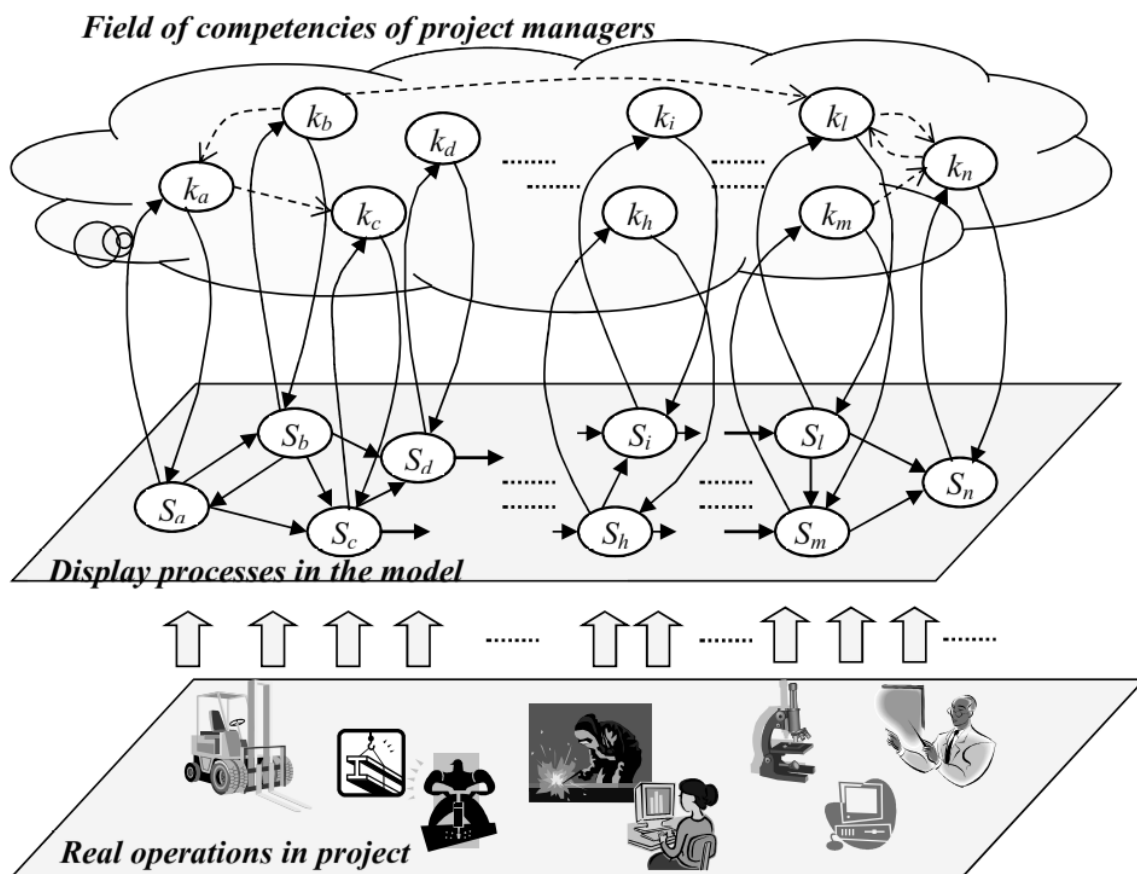

Fig. 2. General concept of creating the manager’s job model

Let us explain the notation of states in Fig. 3 and their compliance with the project manager’s instructions, which is personally responsible for [18-21]:

1. Output plan, putting on manufacture;
2. Management of material resources, including infrastructure;
3. HR-management: need, qualification level, labor protection;
4. Production management;
5. Management of non-conforming Product;
6. Product pricing;
7. Implementation of preventive measures.

The Project Manager participates in:

8. Analysis and improvement of QMS, development of output plans;
9. Product supply contracts;
10. Procurement contracts;
11. Technological preparation of manufacture;
12. All kinds of Product tests;
13. Personnel training, including special processes, certification.

14. Analysis of causes of defects, results of control, development of preventive measures for the elimination of defects.

The Project Manager is informed and knows:

15. Output Plan; Innovation Plan (IP);
16. Manufacturing facilities, specialization of subdivision, measuring facilities;
17. Technical Output Documentation, Market Situation, progress of contracts;
18. Identification, acceptance control, terms of the Product delivery;
19. Security of manufacture with technical documentation;
20. Organizational structure of the Quality Management System, subordination, procedures, responsibility;
21. Basics of labor law; Regulatory Documentation on labor protection and safety, industrial hygiene, fire and environmental safety.

Oriented state graph presented in Fig. 3, can serve as a basis for constructing a Markov model of a project manager’s activity.

For this, it is necessary to add an additional link in each of the 21 states, which characterizes the ability of the system to remain in the initial state. In fact, this relationship corresponds to the transition of the manager to the field of competence. Wherein the project manager does not have the knowledge necessary to solve the process tasks, then the proportion of time for “independent work” in the virtual area of competence will be quite large, including training / self-study or searching for the best practice examples.

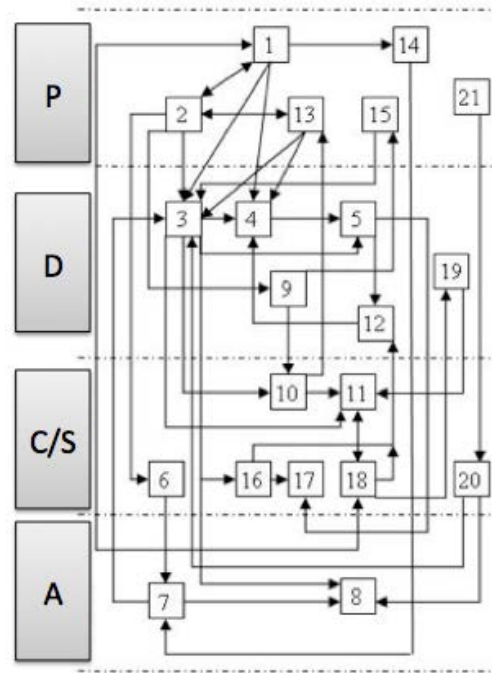

Fig. 3. PM's profile based on competency analysis

The oriented graph obtained after complementing the links can be represented using the adjacency matrix (Fig. 4).

Each non-zero and equal to 1 element of the adjacency matrix c_{ij} means the presence of a direct connection between states $i \rightarrow j$. The values of the elements of the main diagonal $c_{ii} = 1$ indicate the presence of a transition loop when the system remains in the same state.

Each row of the adjacency matrix indicates the presence of transitions to other system states. As is known, all possible transitions from a certain state to other states constitute a complete group of events, i.e. one of the transitions must be implemented.

The sum of the probabilities of all states $p_i(k)$ at each step k is 1 [30-31].

This allows you to enter the norm for each row of the matrix $\|c_{ij}\|$ with the replacement of values $c_{ij} = 1$ with transition probabilities $\pi_{ij} > 0$ with the fulfillment of the condition that is valid for the full group of events:

$$\sum_{j=1}^m \pi_{ij} = 1, \quad \{i = 1, 2, \dots, m\}, \quad (1)$$

where: $m = 21$ – number of possible system states.

The matrix of transition probabilities is written as follows.

$$\sum_{i=1}^m p_i(k) = 1, \quad (2)$$

where: $p_i(k)$ – probability of the i -th state on the step k .

		Transition to the state																					
		1	2	3	4	5	6	7	8	9	10	11	12	13	14	15	16	17	18	19	20	21	
Transition from the state	1	c _{1,1}	c _{1,2}	c _{1,3}	c _{1,4}																	c _{1,14}	
	2	c _{2,1}	c _{2,2}	c _{2,3}			c _{2,6}				c _{2,9}				c _{2,13}								
	3			c _{3,3}	c _{3,4}	c _{3,5}	c _{3,6}		c _{3,8}		c _{3,10}	c _{3,11}						c _{3,16}					c _{3,21}
	4				c _{4,4}	c _{4,5}																	
	5					c _{5,5}								c _{5,12}		c _{5,14}				c _{5,17}			
	6						c _{6,6}	c _{6,7}															
	7								c _{7,7}	c _{7,8}													
	8				c _{8,3}					c _{8,8}													
	9										c _{9,9}	c _{9,10}						c _{9,15}					
	10											c _{10,10}	c _{10,11}		c _{10,13}								
	11												c _{11,11}									c _{11,18}	
	12					c _{12,4}								c _{12,12}									
	13						c _{13,2}	c _{13,3}	c _{13,4}						c _{13,13}								
	14									c _{14,7}						c _{14,14}							
	15																c _{15,15}						
	16													c _{16,12}				c _{16,16}	c _{16,17}				
	17						c _{17,5}													c _{17,17}			
	18	c _{18,1}											c _{18,11}	c _{18,12}							c _{18,18}	c _{18,19}	
	19												c _{19,11}									c _{19,19}	
	20					c _{20,3}					c _{20,8}												c _{20,20}
	21						c _{21,3}																c _{21,20} c _{21,21}

Fig. 4. Adjacency matrix of processes, which are carried out by the project manager

In a homogeneous Markov chain with discrete states and discrete time, as the time changes (step k), the distribution of probabilities of the states $\{p_1(k), p_2(k), \dots, p_m(k)\}$ changes. In this case, the calculation of the probability distribution at each subsequent $(k + 1)$ step is performed in the general case using the well-known formula for the total probability [29; 31]:

$$\begin{pmatrix} p_1(k+1) \\ p_2(k+1) \\ \vdots \\ p_{20}(k+1) \\ p_{21}(k+1) \end{pmatrix}^T = \begin{pmatrix} p_1(k) \\ p_2(k) \\ \vdots \\ p_{20}(k) \\ p_{21}(k) \end{pmatrix}^T \begin{pmatrix} \pi_{1,1} & \pi_{1,2} & \dots & \pi_{1,20} & \pi_{1,21} \\ \pi_{2,1} & \pi_{2,2} & \dots & \pi_{2,20} & \pi_{2,21} \\ \vdots & \vdots & \ddots & \vdots & \vdots \\ \pi_{20,1} & \pi_{20,2} & \dots & \pi_{20,20} & \pi_{20,21} \\ \pi_{21,1} & \pi_{21,2} & \dots & \pi_{21,20} & \pi_{21,21} \end{pmatrix} \quad (3)$$

where: T – transposition mark.

Therefore, if the matrix of transition probabilities $\|\pi_{ij}\|$ is given and the probability distribution of states $\{p_1(k), p_2(k), \dots, p_m(k)\}$ is known at step k , then the new probability distribution of states $\|p_i(k + 1); i = 1, 2, \dots, m\|$ can be found by the above formula.

Improving operations and processes that may lead to a change in transition probabilities is the basis for improving the system. In this case, a necessary condition for the effective system development is the use of information technologies and the project manager's rational choice of the purpose.

Checking the model performance

In Fig. 5, Fig. 6, Fig. 7 the results of modeling the state of the system for the initial data given in Table 3 are shown.

Transitional probabilities are based on the peer review. For the initial data corresponding to a certain level of perfection of the enterprise management system, the results obtained adequately reflect the project management trends. At the same time, the level of control perfection assumes the existence of a totality for each of the 21 states of conditional transition probabilities, depending on the ratio of the time to complete the task and the operations of transitions to other tasks.

For clarity of presentation of modeling results, the calculation data were divided into the corresponding groups: change of states 1–7 corresponds to the project manager's personal responsibility (Fig. 5); states 8-14 corresponds to the co-executor (Fig. 6), states 15-21 correspond to the states of awareness (Fig. 7).

Due to the fact that the transition probabilities of the system correlate with the execution time of the processes, the project manager's overall workload can be estimated (Fig. 8).

The ratio of time for the execution of a group of processes is: $\sum_{1-7} p_i(k) : \sum_{8-14} p_i(k) : \sum_{15-21} p_i(k) = 0,5 : 0,3 : 0,2 = 2,5 : 1,5 : 1$.

If the condition that related groups of processes differ in time consuming twice is accepted, then the ratio should be ideal:

$$\sum_{1-7} p_i(k) : \sum_{8-14} p_i(k) : \sum_{15-21} p_i(k) = 4:2:1.$$

The results obtained for this project manager indicate that there is a slight increase in the proportion of time that is allocated to information processes to the detriment of other project processes.

Table 3. Transition probability matrix

	1	2	3	4	5	6	7	8	9	10	11	12	13	14	15	16	17	18	19	20	21
1	0,58	0,1	0,15	0,1	0	0	0	0	0	0	0	0	0	0,07	0	0	0	0	0	0	0
2	0,25	0,35	0,1	0	0	0,1	0	0	0,1	0	0	0	0,1	0	0	0	0	0	0	0	0
3	0	0	0,20	0,2	0,05	0,1	0	0,05	0	0,10	0,1	0	0	0	0	0,1	0	0	0	0	0,1
4	0	0	0	0,8	0,2	0	0	0	0	0	0	0	0	0	0	0	0	0	0	0	0
5	0	0	0	0	0,25	0	0	0	0	0	0	0,25	0	0,3	0	0	0,2	0	0	0	0
6	0	0	0	0	0	0,6	0,4	0	0	0	0	0	0	0	0	0	0	0	0	0	0
7	0	0	0,2	0	0	0,1	0,6	0,1	0	0	0	0	0	0	0	0	0	0	0	0	0
8	0	0	0,4	0	0	0	0	0,6	0	0	0	0	0	0	0	0	0	0	0	0	0
9	0	0	0	0	0	0	0	0	0,5	0,2	0	0	0	0	0,3	0	0	0	0	0	0
10	0	0	0	0	0	0	0	0	0	0,7	0,1	0	0,2	0	0	0	0	0	0	0	0
11	0	0	0	0	0	0	0	0	0	0	0,8	0	0	0	0	0	0	0	0,2	0	0
12	0	0	0	0,3	0	0	0	0	0	0	0	0,7	0	0	0	0	0	0	0	0	0
13	0	0,2	0,1	0,05	0	0	0	0	0	0	0	0	0,65	0	0	0	0	0	0	0	0
14	0	0	0	0	0	0	0,4	0	0	0	0	0	0	0,6	0	0	0	0	0	0	0
15	0	0	0,4	0	0	0	0	0	0	0	0	0	0	0	0,6	0	0	0	0	0	0
16	0	0	0	0	0	0	0	0	0	0	0	0,2	0	0	0	0,5	0,3	0	0	0	0
17	0	0	0	0	0,35	0	0	0	0	0	0	0	0	0	0	0	0,65	0	0	0	0
18	0,2	0	0	0	0	0	0	0	0	0	0,05	0,05	0	0	0	0	0	0,45	0,25	0	0
19	0	0	0	0	0	0	0	0	0	0	0,3	0	0	0	0	0	0	0	0,7	0	0
20	0	0	0,2	0	0	0	0	0,1	0	0	0	0	0	0	0	0	0	0	0	0,7	0
21	0	0	0,02	0	0	0	0	0	0	0	0	0	0	0	0	0	0	0	0	0,05	0,93

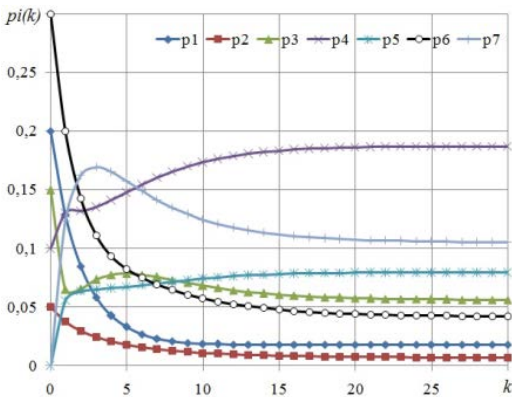

Fig. 5. Change of states 1-7 corresponds to the project manager's personal responsibility

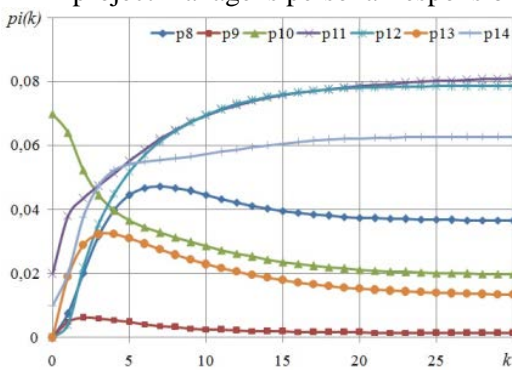

Fig. 6. Change of states 8-14 corresponds to the manager, as a co-executor

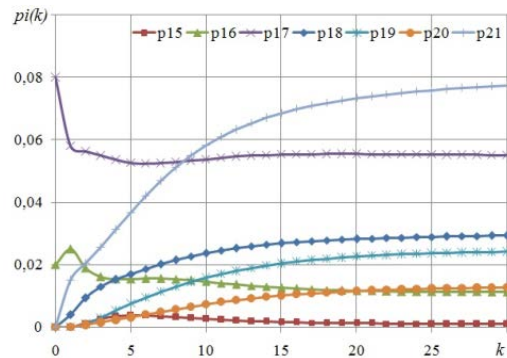

Fig. 7. Change of states 15-21 corresponds to the states of the project manager's awareness

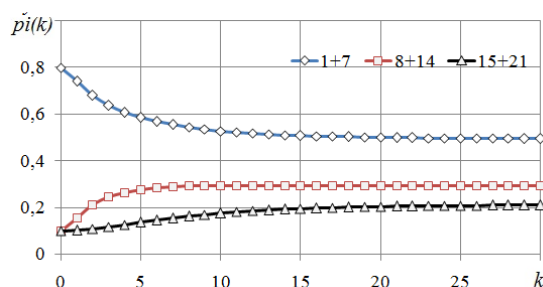

Fig. 8. Assessment of the project manager's workload for the implementation of the relevant process groups

As follows from the modeling results (Fig. 5), the largest time consuming corresponds to $p_4(30) = 0.19$, i.e. Product management. The following are the processes: $p_7(30) = 0.105$ – implementation of control and preventive measures; $p_5(30) = 0.08$ control of nonconforming Product. All other processes: $p_3(30) = 0.06$; $p_6(30) = 0.04$; $p_1(30) = 0.02$; $p_2(30) = 0.007$ require less time.

Conclusions. The article discusses the practical aspects of profiling knowledge in project management taking into account the possession of competencies and the availability of experience for various categories of specialists involved in the project. It is shown that the success of the project activities of organizations substantially depends on the professional training of personnel and the project manager's quality work.

Market pressure on project activities is associated with a rapid reduction in the life cycles of technologies and products, which significantly increases the responsibility of project managers for the ultimate fate of their project outputs. At the same time, there are more and more situations when, under extremely short deadlines, it is necessary to make a decision on the project team formation or on the choice of a project manager with the necessary competences to implement a project and successfully complete it.

In light of recent trends in standardization and operationalization of project activities, a general concept of forming the project manager's job descriptions is proposed. Each instruction point is formed at the intersection of three coordinates: the performer, the work and the competence.

The performed studies, on the one hand, characterize the quality and performance of the presented model. On the other hand, they allow us to show the possibility of applying the model to improve the project manager's activities by identifying “bottlenecks” and performing corrective actions of his duties, regulated by job descriptions.

A Markov model of the Project Manager's changing states has been developed, which describes the system using homogeneous Markov chains with discrete states and time. Discrete states (21 processes) of the Product Manager form a specific structure of communications and interaction of project processes, which take into account the system topology and contextual features of project processes.

References

1. Belbin, R. M. (2003). “Komandy menedzherov. Sekrety uspeha i prichiny neudach”. [Management teams. Secrets of success and reasons for failure], Moscow, Russian Federation, *Publ. HIPPO*, 321p. (in Russian).
2. Bujmov, A. G. (2005). “O prirode nedostatochnoj nadezhnosti testa Belbina”. [On the nature of the insufficient reliability of the Belbin test]. *Management in Russia and abroad*, (2), 129-138 [digital resource] – Available at : <http://dis.ru/library/559/25601/>. Active link – 10.05.19 (in Russian).
3. Kolesnikova K. V., Vlasenko O. V., Lukyanow D. V. & Olech T. M. (2013). “Zarządzanie projektami w systemach organizacyjnych i technicznych – model komunikacji Markowa”. [Markow's model in project management communications in organizational i technical systems], *Spoleczno-ekonomiczne uwarunkowania zarzadzania i administracji – innowacyjność, komunikacja*. Pod red. Mariana Duczmala, Tadeusza Pokusy, *Wyd. WSZiA, Instytut Śląski*, pp. 223- 232 (in English).
4. Belbin, R. M. (1997). “Roli v komande i samoocenka predpochitaemyh vami rolej”. [Team Roles and Self-Assessment of Your Preferred Roles]. *Effective manager: views and illustrations*, Zhukovsky, Russian Federation, *Publ. MCDO LINK* (in Russian).
5. Sherstyuk O., Olekh T., & Kolesnikova K. (2016). “The research on role differentiation as a method of forming the project team”, *Eastern-European journal of enterprise technologies*, No. 2 (3), pp. 63-68 (in English).
6. Sherstyuk, O. I., & Gogunskij, V. D. (2013). “Imperativ kompetentnosti ili ravnovesie rolej v komande proekta”. [Imperative competency or balance of roles in the project team], pp. 390-391, Nikolaev, Ukraine, *Publ. NUK* (in Russian).
7. (2019). “ICB: IPMA Competence Baseline” [digital resource] – Available at : <http://ipma.ch/resources/media/ipma-publications/ipma-competence-baseline/> Active link – 10.05.19 (in English)
8. (2019). “PMI certification” [digital resource] – Available at : <http://www.pmi.org/Certification.aspx> Active link – 10.05.19 (in English).
9. (2019). “PgMP certification” [digital resource] – Available at : <https://www.pmi.org/certifications/types/program-management-pgmp>. Active link – 12.05.19.

10. Heywood, L., Gonczi, A., & Hager, P. (1992). "A guide to development of competency standards for professions". Canberra: AGPS.
11. Lukyanov, D. V. (2008). "Dinamika razvitiya proektnogo menedzhera. Instrumenty ocenki potencialnoj uspešnosti menedzhera v novoj roli. Model Belbina". [The dynamics of the project manager. Tools for assessing the potential success of a manager in a new role. Belbin Model] [digital resource] – Available at: <http://www.sovnet.ru/library/publications/2554>. – Active link – 10.05.19 (in Russian)
12. Fesenko, T. G. (2011). "Formuvannya modeli "competence work" komandi upravlinnya budivelnim proektom iz vikoristannyam NCB UA Version 3.0". [Formation of the "Competence work" model in the construction project management team using NCB UA 3.0], *Eastern-European journal of enterprise technologies*, 1/7 (49), pp. 53-57 (in Ukrainian).
13. Basinskaya, I. V., Radyuk, O. M., & Lukyanov, D. V. (2011). "Vzaimosvyaz stressogennosti povedencheskih kompetencij i uslovij zhizni s kreativnostyu i emocionalnym stressom u rukovoditelej srednego i vysshego zvena". [The relationship of stressfulness of behavioral competencies and living conditions with creativity and emotional stress among middle and senior managers], Kyiv, Ukraine, *Publ. KNUBA*, pp.28-32 (in Russian).
14. Gogunskii, V. D., Luk'yanov, D. V., & Vlasenko, O. V. (2012). "Viznachennya yader znan na grafi kompetencij proektnih menedzheriv", [Determining knowledge cores in the project manager competency graph], *Eastern-European journal of enterprise technologies*, 1(10 (55)), pp. 26-28 (in Russian).
15. Beloshickij, A. A. (2012). "Upravlenie problemami v metodologii proektno-vektornogo upravleniya obrazovatel'nimi sredami". [Problem management in the methodology of project-vector management of educational environments], *Management of Development of Complex Systems*, No. (9), pp.104-107 (in Russian).
16. Raudis, Sh., & Yustickis, V. (2008). "Zakon Jerksa-Dodsona: svyaz mezhdru stimulirovaniem i uspešnostyu naucheniya". [Yerkes Dodson's Law: The Link Between Stimulation and Learning Success]. *Psychology issues*, No. (3), pp.119-126 (in Russian).
17. (2019). "Project Manager Job Description" [digital resource] – Available at: <https://www.topresume.com/career-advice/project-manager>. Active link – 17.07.19.
18. (2019). "Project Manager job description guide" [digital resource] – Available at: <https://www.roberthalf.com.au/our-services/financial-services/project-manager-jobs>. Active link – 16.07.19.
19. (2019). "Roles and responsibilities of the Project Manager" [digital resource] – Available at: <https://www.finance-ni.gov.uk/articles/roles-and-responsibilities-project-manager/> Active link – 17.07.19.
20. (2019). "Project Manager Job Description" [digital resource] – Available at: <https://www.projectmanager.com/blog/project-manager-job-description>. Active link – 01.08.19.
21. (2019). "IPMA standards – Individual Competence Baseline (ICB)" [digital resource] – Available at: <https://www.ipma.world/individuals/standard/>. Active link – 15.05.19.
22. Haughey, D. (2017). "RACI matrix. Project Smart" [digital resource] – Available at: <https://www.projectsmantr.co.uk/raci-matrix.php>. Active link – 17.07.19.
23. Lukianov, D., Bespanskaya-Paulenko, K., Gogunskii, V., Kolesnikov, O., Moskaliuk, A., & Dmitrenko, K. (2017). "Development of the markov model of a project as a system of role communications in a team", *Eastern-European journal of enterprise technologies*, (3 (3)), pp. 21-28. Available at: <http://journals.uran.ua/eejet/article/view/103231>. Active link – 07.07.19.
24. Gogunskii, V., Kolesnikov, O., Oborska, G., Moskaliuk, A., Kolesnikova, K., Harelik, S., & Lukianov, D. (2017). "Representation of project systems using the markov chain", *Eastern-European journal of enterprise technologies*, (2 (3)), 60-65. Available at: <http://journals.uran.ua/eejet/article/view/97883>. Active link – 07.07.19.
25. Beloshickij, A. A. (2011). "Ponyatijnyj bazis metodologii proektno-vektornogo upravleniya vysshimi uchebnymi zavedeniyami". [The conceptual basis of the methodology of project-vector management of educational environments]. *Project management and production development: a collection of scientific papers*, Lugansk, Ukraine, SNU im. V. Dahl, (2 (38)), pp.25-31 (in Russian).
26. Vajsman, V. O. (2009). "Modeli, metodi ta mehanizmi stvorenniya i funkcionuvannya proektno-kerovanoyi organizaciyi". [Models, methods and mechanisms of creation and functioning of a project-managed organization], Kyiv, Ukraine, *Publ. "Scientific world"*, 146 p. (in Ukrainian)
27. Miller, G. A. (1956). "The magical number seven, plus or minus two: Some limits on our

capacity for processing information”, *Psychological review*, No. 63(2), pp. 81-97.

28. Ostakhov, V., Artykulna, N., & Morozov, V. (2018). “Models of IT Projects KPIs and Metrics”. In *2018 IEEE Second International Conference on Data Stream Mining & Processing*, pp. 50-55.

29. Olekh, T., Piterska, V., Kolesnikov, O., & Gogunskii, V. (2018). “Development of the Markovian model for the life cycle of a project’s benefits”, *Eastern-European journal of enterprise technologies*, No. 5(4 (95)), pp. 30-39.

30. Kolesnikov, O., Gogunskii, V., Kolesnikova, K., Lukianov, D., & Olekh, T. (2016). “Development

of the model of interaction among the project, team of project and project environment in project system”, *Eastern-European journal of enterprise technologies*, No. (5 (9)), pp. 20-26.

31. Kolesnikova, K., Lukianov, D., Gogunskii, V., Iakovenko, V., Oborska, G., Negri, A., & Bepanskaya-Paulenka, K. (2017). “Communication management in social networks for the actualization of publications in the world scientific community on the example of the network ResearchGate”, *Eastern-European journal of enterprise technologies*, No. 3(4), pp. 27-35.

Received 21.05.2019

УДК 005.8

¹**Колесників, Олексій Євгенович**, канд. техніч. наук, доцент, доцент каф. управління системами безпеки життєдіяльності, E-mail: kae@opu.ua, Scopus ID: 57192559239,

ORCID: <http://orcid.org/0000-0003-2366-1920>

²**Лук’янов, Дмитро Володимирович**, канд. техніч. наук, доцент, професор кафедри загальної та клінічної психології, E-mail: lukianov@bsu.by, Scopus ID: 57192572835,

ORCID: <http://orcid.org/0000-0001-8305-2217>

³**Шерстюк, Ольга Ігорівна**, канд. техніч. наук, каф. «Менеджмент і Маркетинг», E-mail: sherstyuk1990@bk.ru, ORCID: <http://orcid.org/0000-0002-0482-2656>

⁴**Колеснікова, Катерина Вікторівна**, доктор техніч. наук, професор каф. технологій управління, E-mail: amberk4@gmail.com, Scopus ID: 57188623059, ORCID: <https://orcid.org/0000-0002-9160-5982>

¹Одеський національний політехнічний університет, пр. Шевченка, 1, м. Одеса, Україна, 65044

²Білоруський державний університет, пр. Незалежності, 4, м. Мінськ, Республіка Білорусь, 220030

³Одеський національний морський університет, вул. Мечникова, 34, м. Одеса, Україна, 65029

⁴Київський національний університет імені Тараса Шевченка, вул. Володимирська, 60, м. Київ, Україна, 01033

ПОСАДОВА ІНСТРУКЦІЯ ПРОЕКТНОГО МЕНЕДЖЕРА ЯК ОДИН З КЛЮЧОВИХ ФАКТОРІВ УСПІХУ ПРОЕКТНОГО УПРАВЛІННЯ

Анотація: У статті розглянуто практичні аспекти профілізації знань в області управління проектами з урахуванням володіння компетенціями і наявності досвіду у різних категорії фахівців, зайнятих в управлінні проектами. Показано, що успішність проектної діяльності організацій істотно залежить від професійної підготовки персоналу і правильного формування посадових інструкцій учасників проектної діяльності. Запропоновано загальну концепцію формування посадових інструкцій. Розроблено марківська модель зміни станів менеджера проекту, яка описує систему за допомогою однорідних марківських ланцюгів з дискретними станами і часом. Надано рекомендації щодо використання запропонованого інструментарію для комплектування команди проекту.

Ключові слова: управління проектами; команда проекту; матриця відповідальності; компетенції; марковський ланцюг; модель робіт проектного менеджера

УДК 005.8

¹**Колесников, Алексей Евгеньевич**, канд. технич. наук, доцент, доцент каф. управления системами безопасности жизнедеятельности, E-mail: kae@opu.ua, Scopus ID: 57192559239,

ORCID: <http://orcid.org/0000-0003-2366-1920>

²**Лукьянов, Дмитрий Владимирович**, канд. технич. наук, доцент, доцент каф. общей и клинической психологии, E-mail: lukianov@bsu.by, Scopus ID: 57192572835,

ORCID: <http://orcid.org/0000-0001-8305-2217>

³**Шерстюк, Ольга Игоревна**, канд. технич. наук, каф. «Менеджмента и маркетинга»,

E-mail: sherstyuk1990@bk.ru, ORCID: <http://orcid.org/0000-0002-0482-2656>

⁴**Колесникова, Екатерина Викторовна**, д-р технич. наук, профессор каф. технологий управления,

E-mail: amberk4@gmail.com, Scopus ID: 57188623059, ORCID: <https://orcid.org/0000-0002-9160-5982>

¹Одесский национальный политехнический университет, пр. Шевченко, 1, г. Одесса, Украина, 65044

²Белорусский государственный университет, пр. Независимости, 4, г. Минск, Республика Беларусь, 220030

³Одесский национальный морской университет, ул. Мечникова, 34, г. Одеса, Украина, 65029

⁴Киевский национальный университет имени Тараса Шевченко, ул. Владимирская, 60, г. Киев, Украина, 01033

ДОЛЖНОСТНАЯ ИНСТРУКЦИЯ ПРОЕКТНОГО МЕНЕДЖЕРА КАК ОДИН ИЗ КЛЮЧЕВЫХ ФАКТОРОВ УСПЕХА ПРОЕКТНОГО УПРАВЛЕНИЯ

Аннотация: В статье рассмотрены практические аспекты профилирования знаний в области управления проектами с учетом владения компетенциями и наличием опыта для различных категорий специалистов, занятых в управлении проектами. Показано, что успешность проектной деятельности организаций существенно зависит от профессиональной подготовки персонала и правильного формирования должностных инструкций участников проектной деятельности. Предложена общая концепция формирования должностных инструкций. Разработана марковская модель изменения состояний Менеджера проекта, которая описывает систему с помощью однородных марковских цепей с дискретными состояниями и временем. Даны рекомендации по использованию предложенного инструментария для комплектования команды проекта.

Ключевые слова: управление проектами; команда проекта; компетенции; матрица ответственности; марковская цепь; модель работ менеджера



Oleksii E. Kolesnikov, Candidate of Technical Sciences,
Associate Professor

Research field: Information technology in educational projects, project teambuilding, knowledge management



Dmytro V. Lukianov, Candidate of Technical Sciences,
Associate Professor

Research field: Project management, strategic management, development of professional standards, knowledge management



Olha I. Sherstyuk, Candidate of Technical Sciences,
Associate Professor

Research field: Project teambuilding, knowledge management systems, emotional intelligence in project management



Kateryna V. Kolesnikova, Doctor of Technical Sciences,
Professor

Research field: Project management, knowledge management, modeling of complex objects and systems