

UDC 519.6:531.5

Alla L. Rachinskaya<sup>1</sup>, Candidate of Physical and Mathematical Sciences, Associate Professor, Associate Professor of the Department of Theoretical Mechanics, E-mail: rachinskaya@onu.edu.ua, ORCID: org/0000-0003-2430-9603

<sup>1</sup>Odessa National University I.I. Mechnikov, Dvoryanskaya str., 2, Odessa, Ukraine, 65082

**MODELING THE MOTION OF A SOLID BODY UNDER THE ACTION OF THE MOMENT OF LIGHT PRESSURE IN THE MEDIUM WITH RESISTANCE**

**Annotation.** *The paper describes the simulation of fast rotational motion of a dynamically asymmetric satellite relative to the centre of mass under the influence of the joint effect of the moment of forces of light pressure and resistance. It is assumed that the surface of the spacecraft is a surface of revolution. The medium creates a weak resistance proportional to the angular velocity of the rigid body's own rotation relative to the centre of mass. Orbital motions with an arbitrary eccentricity are considered given. The mathematical model of satellite motion in this formulation is described by a rigid system of differential equations: the fast variables are Euler angles, and the slow variables are the modulus of the angular momentum vector, the kinetic energy, and the angles of orientation of the angular momentum vector in space. Averaging is performed over the Euler-Poinsot motion. The averaged system of equations of body motion allows numerical simulation of the satellite's motion relative to the centre of mass. The study is carried out in a dimensionless form for a multiparameter system of equations. For numerical calculation, an implicit third-order Adams method is used to integrate systems of differential equations. A personal computational package was developed for the constructed mathematical model of the satellite, as well as a library for calculating the complete elliptic integrals of the first and second kinds. Numerical calculation allows one to obtain the functions of modulating the modulus of the satellite kinetic moment vector, its orientation angles to the orbit, as well as the satellite kinetic energy values. The analysis of the influence of the parameters of the problem on the nature of the motion of the satellite relative to the centre of mass is carried out. A qualitative picture was obtained of the influence of the initial values of the angles of orientation of the kinetic moment vector, the geometry of the masses, the eccentricity of the orbit, the characteristic numbers of disturbing moments on the hodograph character of the kinetic moment vector. The hodograph of the kinetic moment vector in three-dimensional space is simulated for various values of the system parameters. To construct three-dimensional objects on the scene, according to the carried out numerical calculations, we developed our own software using DirectX technology in C# language, simulating a virtual laboratory of a numerical experiment.*

**Keywords:** mass geometry; hodograph; kinetic moment; light pressure; resistance, satellite

**Introduction.** The study of the problems of the gyration of rigid bodies about a fixed point has remained relevant for many decades. This is due to the increasing demands on the accuracy of solving practical problems of cosmonautics, gyroscopy, etc.

The development of our own packages for modelling mechanical processes allows us to study the motion of a rigid body relative to a fixed point under the action of various force factors, as well as their combination. For each force factor, the necessary physical and mathematical models are constructed, and the question of the interaction of force factors is also investigated. To generalize the results obtained, it is necessary to build models in a dimensionless form, choosing the characteristic parameters of the problem as the scale.

One of the important characteristics of the rotational motion of a solid relative to a fixed point is the vector of angular (kinetic) momentum. The hodograph of this vector is a spatial curve that allows you to explore the nature of the motion of a rigid body and determine the necessary relationships between the parameters of the model.

**Survey of prior research and formulation of the problem.** The motion of rigid bodies about a fixed point in [1-11] composed of the Euler-Poinsot motion around the vector of the angular momentum

and the motion of the vector of the angular momentum itself. If the body is not affected by the moments of applied forces, then it makes some movement, which is called unperturbed and is the Euler-Poinsot movement. In real conditions, the disturbing moments of external and internal forces act on the body. Such a movement is called perturbed. The task of studying the rotational motion of a spacecraft under the action of a moment of light pressure force is one of the most important sections of the dynamics of the rotational motion of a rigid body relative to the centre of mass. The works [1-19] are devoted to the study of perturbed motions of a rigid body under the action of moments of forces of different physical nature (gravitational [1], light pressure [2-4; 13-16], influence of a cavity filled with a viscous fluid [5; 17-19], resistance [6-7], etc.) The task of studying the rotational motion of a spacecraft under the action of a moment of light pressure force is one of the most important sections of the dynamics of the rotational motion of a rigid body relative to the centre of mass. Initially, satellites and spacecraft equipped with extended solar panels or reflecting antennas were studied. Then came the task of controlling orientation using light pressure. A literature on these issues can be found in the book [13] and the review [14]. In [2], the integral characteristics of the force effect of the light pressure on the body of the flight device were obtained, and formulas for the moment

© A. Rachinskaya; 2019

This is an open access article under the CC BY license (<http://creativecommons.org/licenses/by/4.0/deed.uk>)

of the forces of light pressure acting on the body bounded by the surface of rotation were given. The second research direction is the effect of light pressure on the rotational-translational motion of asteroids [15]. The third direction is the study of the Yarkovsky effect [16].

The rapid development of IT-technologies allows not only to apply new methods of research tasks, but also to carry out modelling of the studied processes [11; 20; 21].

**The purpose and objectives of the study.** The main goal of the study is to simulate the hodograph of the kinetic momentum vector for various values of the parameters of the disturbing moments to conduct a qualitative analysis of the influence of the disturbing moments on the satellite's motion relative to the centre of mass.

To achieve this goal, the following tasks were set:

building a mathematical model of the motion of a rigid body relative to the centre of mass in a medium with resistance under the action of the moment of force of light pressure;

numerical experiment at various values of parameters of disturbing moments;

three-dimensional modelling of the hodograph of the kinetic momentum vector.

**Building of a mathematical model.** Consider the motion of the satellite relative to the centre of mass under the action of the joint influence of the light pressure and resistance forces' moments. Rotational motions are considered within the framework of a model of a rigid body whose centre of mass moves along a given fixed elliptical orbit around the Sun [1].

Introduce three Cartesian coordinate systems whose origin is compatible with the center of inertia of the satellite [1]. The coordinate system  $Ox_i$  ( $i=1,2,3$ ) moves progressively along with the center of inertia: the axis  $Ox_1$  is parallel to the orbit perihelion radius vector, the axis  $Ox_2$  is the velocity vector of the center of mass of the satellite at the perihelion, and the axis  $Ox_3$  is normal to the orbit plane. The coordinate system  $Oy_i$  ( $i=1,2,3$ ) is associated with the vector of kinetic moment  $\mathbf{G}$ . The axis  $Oy_3$  is directed along the vector of the kinetic moment  $\mathbf{G}$ , the axis  $Oy_2$  lies in the plane of the orbit (ie, in the plane  $Ox_1x_2$ ), the axis  $Oy_1$  lies in the plane  $Ox_3y_3$  and is directed so that the vectors  $\mathbf{y}_1, \mathbf{y}_2, \mathbf{y}_3$  form the right triple [1]. The axes of the

coordinate system  $Oz_i$  ( $i=1,2,3$ ) are associated with the main central axes of inertia of the rigid body. The mutual position of the main central axes of inertia and the axes  $Oy_i$  is determined by the Euler angles. In this case, the direction cosines  $\alpha_{ij}$  of the axes  $z_i$  relative to the system  $Oy_i$  are expressed in terms of the Euler angles  $\varphi, \psi, \theta$  according to known formulas [1]. The position of the angular momentum vector  $\mathbf{G}$  with respect to its center of mass in the coordinate system  $Ox_i$  is determined by the angles  $\lambda$  and  $\delta$ , as shown in [1].

The equations of motion of the body relative to the center of mass are written in the form [1]:

$$\begin{aligned} \frac{dG}{dt} &= L_3, \quad \frac{d\delta}{dt} = \frac{L_1}{G}, \quad \frac{d\lambda}{dt} = \frac{L_2}{G \sin \delta}, \\ \frac{d\theta}{dt} &= G \sin \theta \sin \varphi \cos \varphi \left( \frac{1}{A_1} - \frac{1}{A_2} \right) + \\ &+ \frac{L_2 \cos \psi - L_1 \sin \psi}{G}, \\ \frac{d\varphi}{dt} &= G \cos \theta \left( \frac{1}{A_3} - \frac{\sin^2 \varphi}{A_1} - \frac{\cos^2 \varphi}{A_2} \right) + \\ &+ \frac{L_1 \cos \psi + L_2 \sin \psi}{G \sin \theta}, \\ \frac{d\psi}{dt} &= G \left( \frac{\sin^2 \varphi}{A_1} + \frac{\cos^2 \varphi}{A_2} \right) - \\ &- \frac{L_1 \cos \psi + L_2 \sin \psi}{G} \operatorname{ctg} \theta - \frac{L_2}{G} \operatorname{ctg} \delta. \end{aligned} \quad (1)$$

Here  $L_i$  are the moments of external forces relative to the axes  $Oy_i$ ,  $G$  is the magnitude of the kinetic moment,  $A_i$  ( $i=1,2,3$ ) – the main central moments of inertia about the axes  $Oz_i$ .

In some cases, along with the variable  $\theta$  it is convenient to use as an additional variable an important characteristic – kinetic energy  $T$ , the derivative of which has the form:

$$\begin{aligned} \frac{dT}{dt} &= \frac{2T}{G} L_3 + G \sin \theta \left[ \cos \theta \times \right. \\ &\left. \left( \frac{\sin^2 \varphi}{A_1} + \frac{\cos^2 \varphi}{A_2} - \frac{1}{A_3} \right) (L_2 \cos \psi - L_1 \sin \psi) + \right. \\ &\left. + \sin \varphi \cos \varphi \left( \frac{1}{A_1} - \frac{1}{A_2} \right) (L_1 \cos \psi + L_2 \sin \psi) \right]. \end{aligned} \quad (2)$$

The centre of mass of the satellite moves along the Keplerian ellipse with eccentricity  $e$  and orbital period  $Q$ . The dependence of the true anomaly  $\nu$  on time  $t$  is given by the ratio:

$$\frac{d\nu}{dt} = \frac{\omega_0(1+e\cos\nu)^2}{(1-e^2)^{3/2}}, \quad \omega_0 = \frac{2\pi}{Q}, \quad (3)$$

where:  $\omega_0$  is the angular velocity of the orbital motion,  $e$  is the eccentricity of the orbit.

A dynamically asymmetric satellite is considered under the assumption that the angular velocity  $\Omega$  of the satellite's motion relative to the centre of mass is substantially greater than the angular velocity of the orbital motion  $\omega_0$ , i.e.  $\varepsilon = \omega_0 / \omega \sim A_1 \omega_0 / G \ll 1$ . In this case, the kinetic energy of rotation of the body is large compared with the moments of disturbing forces.

The projections  $L_i$  of the moment of external forces are added up from the moment of the forces of light pressure  $L_i^c$  and the moment of forces of external resistance  $L_i^r$ .

Assume that the surface of the spacecraft is a surface of rotation, with the unit vector of the axis of symmetry  $\mathbf{k}$  directed along the axis  $Oz_3$ . As shown in [1; 2], in this case for the moment of the forces of light pressure acting on the satellite, the equation takes the form:

$$\mathbf{L}^c = (a_c(\varepsilon_s) R_0^2 / R^2) \mathbf{e}_r \times \mathbf{k}, \quad (4)$$

$$a_c(\varepsilon_s) \frac{R_0^2}{R^2} = p_c S(\varepsilon_s) Z_0'(\varepsilon_s), \quad p_c = \frac{E_0}{c} \left( \frac{R_0}{R} \right)^2.$$

Here  $\mathbf{e}_r$  is the unit vector in the direction of the radius vector of the orbit;  $\varepsilon_s$  is angle between directions  $\mathbf{e}_r$  and  $\mathbf{k}$  so that  $|\mathbf{e}_r \times \mathbf{k}| = \sin \varepsilon_s$ ;  $R$  is current distance from the centre of the Sun to the centre of mass of the satellite;  $R_0$  is fixed value of  $R$ , for example, at the initial moment of time;  $a_c(\varepsilon_s)$  is a coefficient of moment of light pressure force, determined by surface properties;  $S$  is area of "shadow" on a plane normal to the flow;  $Z_0'$  is a distance from the centre of mass to the centre of pressure;  $p_c$  is light pressure value at a distance  $R$  from the centre of the Sun;  $c$  is the speed of light;

$E_0$  is the magnitude of the energy flow of light pressure at a distance  $R_0$  from the centre of the Sun.

Assume [1] that, due to symmetry, the corresponding function (4) has the form  $a_c = a_c(\cos \varepsilon_s)$  and approximate it by a trigonometric polynomial in degrees of  $\cos \varepsilon_s$ . Represent the function  $a_c(\cos \varepsilon_s)$  as  $a_c = a_0 + a_1 \cos \varepsilon_s + \dots$ . Consider the second term of the expansion,  $a_c(\cos \varepsilon_s) = a_1 \cos \varepsilon_s$ ,  $a_c(\cos \varepsilon_s) = a_1 \cos \varepsilon_s$  when assuming that  $a_1 \sim \varepsilon$ .

It is assumed that the moment of resistance forces  $\mathbf{L}^r$  can be represented in the form  $\mathbf{L}^r = \mathbf{I}\boldsymbol{\omega}$ , where the tensor  $\mathbf{I}$  has constant components  $I_{ij}$  in the system  $Oz_i$ , associated with the body [1, 6]. The medium resistance is assumed to be weak of the order of smallness  $\varepsilon^2$ :  $\|\mathbf{I}\| / G_0 \sim \varepsilon^2 \ll 1$ , where  $\|\mathbf{I}\|$  is the norm of the matrix of resistance coefficients,  $G_0$  is the kinetic moment of the satellite at the initial moment of time..

The projections of the moment of external resistance forces  $L_i^r$  on the axis  $Oy_i$  are written in the form [1; 6]. Here is the projection on the axis  $Oy_1$ , and projections on the other axes have a similar view

$$L_1^r = -G \sum_{i=1}^3 \left( \frac{I_{i1} \alpha_{1i} \alpha_{31}}{A_1} + \frac{I_{i2} \alpha_{1i} \alpha_{32}}{A_2} + \frac{I_{i3} \alpha_{1i} \alpha_{33}}{A_3} \right).$$

**Procedure averaging method.** The task is to study the evolution of satellite rotations on an asymptotically large time interval  $t \gg \varepsilon^{-2}$  over which a significant change in motion parameters occurs.

Consider the unperturbed motion ( $\varepsilon = 0$ ), when the moments of external forces are zero. In this case, the rotation of a rigid body is the Euler-Poinsot motion [22]. Values  $G, \delta, \lambda, T, \nu$  turn into constants, and  $\varphi, \psi, \theta$  are some functions of time  $t$ . The slow variables in the disturbed motion will be  $G, \delta, \lambda, T, \nu$ , and the fast Euler angles  $\varphi, \psi, \theta$ .

Consider movement provided by  $2TA_1 \geq G^2 > 2TA_2$ . Introduce the value

$$k^2 = \frac{(A_2 - A_3)(2TA_1 - G^2)}{(A_1 - A_2)(G^2 - 2TA_3)} \quad (0 < k^2 < 1), \quad (5)$$

that is a constant in undisturbed motion i.e. the modulus of elliptic functions [23] describing this motion.

To construct the averaged system of the first approximation, we substitute the solution of the unperturbed Euler-Poinsot motion [22] to the right-hand members of equations (1) – (2) and conduct averaging over the variable  $\psi$ , and then over the time  $t$ , taking into account the dependence of  $\varphi$ ,  $\psi$  on  $t$  [24]. At the same time, for the slow variables  $\delta$ ,  $\lambda$ ,  $G$ ,  $T$  the former notation is preserved. As a result, we get the following expressions:

$$\begin{aligned} \frac{d\delta}{dt} &= -a_1 R_0^2 (2GR^2)^{-1} H(k^2) \sin \delta \sin 2(\lambda - \nu), \\ \frac{d\lambda}{dt} &= -a_1 R_0^2 (GR^2)^{-1} H(k^2) \cos \delta \cos^2(\lambda - \nu), \\ \frac{dG}{dt} &= -\frac{G}{D(k^2)} \left\{ I_{22} (A_1 - A_3) W(k^2) + \right. \\ &+ I_{33} (A_1 - A_2) [k^2 - W(k^2)] + \\ &+ I_{11} (A_2 - A_3) [1 - W(k^2)] \left. \right\}, \\ \frac{dT}{dt} &= -\frac{2T}{D(k^2)} \left\{ I_{22} (A_1 - A_3) W(k^2) + \right. \\ &+ I_{33} (A_1 - A_2) [k^2 - W(k^2)] + \\ &+ \frac{(A_1 - A_2)(A_1 - A_3)(A_2 - A_3)}{V(k^2)} \times \\ &\times \left\{ \frac{I_{33}}{A_3} [k^2 - W(k^2)] + \frac{I_{22}}{A_2} (1 - k^2) W(k^2) \right\} + \\ &+ \frac{I_{11}}{A_1} \frac{(A_2 - A_3) D(k^2)}{V(k^2)} [1 - W(k^2)] \left. \right\}, \\ W(k^2) &= 1 - \frac{E(k^2)}{K(k^2)}, \\ V(k^2) &= A_2 - A_3 + (A_1 - A_2) k^2 \\ D(k^2) &= A_1 (A_2 - A_3) + A_3 (A_1 - A_2) k^2. \end{aligned} \quad (6)$$

Here  $K(k^2)$  and  $E(k^2)$  are complete elliptic integrals of the first and second kind, respectively [23].

The function  $H(k^2)$  in the first two equations is determined by the ratios:

$$\begin{aligned} H &= \frac{1}{2} \left[ 3a^2 \frac{E(k^2)}{K(k^2)} - 1 \right], \quad \text{if } 2TA_2 - G^2 > 0, \\ H &= \frac{1}{2} \left\{ \frac{3a^2}{k^2} \left[ k^2 - 1 + \frac{E(k^2)}{K(k^2)} \right] - 1 \right\}, \end{aligned}$$

$$\begin{aligned} \text{if } 2TA_2 - G^2 < 0, a^2 &= \frac{\sigma + h}{1 + \sigma}, \sigma = \frac{A_3 (A_1 - A_2)}{A_1 (A_2 - A_3)}, \\ h &= \left( \frac{2T}{G^2} - \frac{1}{A_2} \right) \frac{A_2 A_3}{A_2 - A_3}. \end{aligned} \quad (7)$$

From equations (6) it follows that only the resistance force affects the change in  $G$  and  $T$ . In [6, 8, 9] it was shown that the variables  $G$  and  $T$  strictly decrease for any  $k^2 \in [0, 1]$ .

As is known [1] that  $R = \rho_0 / (1 + e \cos \nu)$ , the focal parameter of the orbit is determined by the equality  $\rho_0 = \eta^{1/3} (1 - e^2) / \omega_0^{2/3}$ , where  $\eta$  is the gravitational constant. Then the first two equations of system (6) for the angles of orientation of the kinetic moment vector will take the form:

$$\begin{aligned} \frac{d\delta}{dt} &= -\frac{a_1 R_0^2 \omega_0^{4/3} (1 + e \cos \nu)^2}{2G \eta^{2/3} (1 - e^2)^2} H \sin \delta \sin 2(\lambda - \nu) \\ \frac{d\lambda}{dt} &= -\frac{a_1 R_0^2 \omega_0^{4/3} (1 + e \cos \nu)^2}{G \eta^{2/3} (1 - e^2)^2} H \cos \delta \cos^2(\lambda - \nu) \end{aligned} \quad (8)$$

After averaging the equation for  $k^2$  will take the form:

$$\begin{aligned} \frac{dk^2}{dt} &= \frac{I_{33} A_1 - I_{11} A_3}{A_1 A_3} \left\{ (1 - \chi)(1 - k^2) - \right. \\ &- \left. [(1 - \chi) + (1 + \chi)k^2] \frac{E(k^2)}{K(k^2)} \right\}, \\ \chi &= \frac{2I_{22} A_1 A_3 - I_{11} A_2 A_3 - I_{33} A_1 A_2}{(I_{33} A_1 - I_{11} A_3) A_2}. \end{aligned} \quad (9)$$

### Numerical analysis of averaged satellite spin.

To conduct a numerical study, we construct a mathematical model in a dimensionless form. To nondimensionalize the system, we take the unit of measurement of time  $\omega_0^{-1}$ , moment of inertia-  $A_1$  and modulus of the vector of kinetic moment - its initial value  $G_0$ , then the dimensionless values of the model are denoted and defined as:

$$\begin{aligned} \tau &= \omega_0 t, \tilde{A}_2 = \frac{A_2}{A_1}, \tilde{A}_3 = \frac{A_3}{A_1}, \tilde{G} = \frac{G}{G_0}, \tilde{T} = \frac{A_1 T}{G_0^2}, \\ \tilde{I}_{ii} &= \frac{I_{ii}}{A_1 \omega_0} \quad (i = 1, 2, 3). \end{aligned}$$

Introduce the dimensionless characteristic number of this mode

$$\chi_1 = \frac{a_1 R_0^2 \omega_0^{1/3}}{G_0 \eta^{2/3}} \quad (10)$$

System (6), taking into account (8), in the dimensionless form takes the form:

$$\frac{d\delta}{d\tau} = -\frac{\chi_1}{2\tilde{G}} \frac{(1+e \cos \nu)^2}{(1-e^2)^2} H(k^2) \sin \delta \sin 2(\lambda - \nu)$$

$$\frac{d\lambda}{d\tau} = -\frac{\chi_1}{\tilde{G}} \frac{(1+e \cos \nu)^2}{(1-e^2)^2} H(k^2) \cos \delta \cos^2(\lambda - \nu)$$

$$\frac{d\tilde{G}}{d\tau} = -\frac{\tilde{G}}{\tilde{D}(k^2)} \left\{ \tilde{I}_{22} (1 - \tilde{A}_3) W(k^2) + \right.$$

$$+ \tilde{I}_{33} (1 - \tilde{A}_2) [k^2 - W(k^2)] +$$

$$\left. + \tilde{I}_{11} (\tilde{A}_2 - \tilde{A}_3) [1 - W(k^2)] \right\},$$

$$\frac{d\tilde{T}}{d\tau} = -\frac{2\tilde{T}}{D(k^2)} \left\{ \tilde{I}_{22} (1 - \tilde{A}_3) W(k^2) + \right.$$

$$+ \tilde{I}_{33} (1 - \tilde{A}_2) [k^2 - W(k^2)] +$$

$$+ \frac{(1 - \tilde{A}_2)(1 - \tilde{A}_3)(\tilde{A}_2 - \tilde{A}_3)}{\tilde{V}(k^2)} \times$$

$$\times \left\{ \frac{\tilde{I}_{33}}{\tilde{A}_3} [k^2 - W(k^2)] + \frac{\tilde{I}_{22}}{\tilde{A}_2} (1 - k^2) W(k^2) \right\} +$$

$$+ \tilde{I}_{11} \frac{(\tilde{A}_2 - \tilde{A}_3) \tilde{D}(k^2)}{\tilde{V}(k^2)} [1 - W(k^2)] \Big\},$$

$$W(k^2) = 1 - \frac{E(k^2)}{K(k^2)}, \tilde{V}(k^2) = \tilde{A}_2 - \tilde{A}_3 + (1 - \tilde{A}_2) k^2$$

$$\tilde{D}(k^2) = (\tilde{A}_2 - \tilde{A}_3) + \tilde{A}_3 (1 - \tilde{A}_2) k^2. \quad (11)$$

Relations (7) after nondimensionalization take the form:

$$H = \frac{1}{2} \left[ 3a^2 \frac{E(k^2)}{K(k^2)} - 1 \right], \quad \text{if} \quad 2\tilde{T}\tilde{A}_2 - \tilde{G}^2 > 0,$$

$$H = \frac{1}{2} \left\{ \frac{3a^2}{k^2} \left[ k^2 - 1 + \frac{E(k^2)}{K(k^2)} \right] - 1 \right\}, \quad \text{if}$$

$$2\tilde{T}\tilde{A}_2 - \tilde{G}^2 < 0,$$

$$a^2 = \frac{\sigma + h}{1 + \sigma}, \sigma = \frac{\tilde{A}_3 (1 - \tilde{A}_2)}{(\tilde{A}_2 - \tilde{A}_3)},$$

$$h = \left( \frac{2\tilde{T}}{\tilde{G}^2} - \frac{1}{\tilde{A}_2} \right) \frac{\tilde{A}_2 \tilde{A}_3}{\tilde{A}_2 - \tilde{A}_3}.$$

Conduct a numerical study for the system of equations (11), and the equations for changing the true anomaly (3) in a dimensionless form:

$$\frac{d\nu}{d\tau} = \frac{(1+e \cos \nu)^2}{(1-e^2)^{3/2}}.$$

Conduct a numerical calculation of the satellite's motion relative to the centre of mass when its centre of mass moves in a circular orbit ( $e = 0$ ). For the moments of inertia of the satellite, set the values  $\tilde{A}_2 = 0.8, \tilde{A}_3 = 0.5$ . The initial values of the angles of orientation of the kinetic moment vector relative to  $Ox_i$  are:  $\delta_0 = 0.33\pi, \lambda_0 = 0$ . The true anomaly at the initial moment of time is  $\nu_0 = 0$ . The module of elliptic functions has the value  $k^2 = 0.5$ . The study is conducted for a small moment of resistance forces with the same coefficients along the three axes of inertia  $I_{11} = I_{22} = I_{33} = 0.01$ . For the characteristic number of the moment of the force of the light pressure we choose the value  $\chi_1 = 1$ .

The result of changing the angle of deviation of the kinetic momentum vector  $\mathbf{G}$  from the axis of the vertical to the satellite orbit plane is shown in Fig. 1, the angle of rotation of the kinetic moment vector about the vertical axis is shown in Fig. 2 From fig. 1, it can be seen that the angle function  $\delta(\tau)$  is periodic with a non-constant amplitude.

The angle function  $\lambda(\tau)$  in Fig. 2 has gaps of ascending and descending, which allows to conclude that at first stage the kinetic momentum vector  $\mathbf{G}$  rotates about the vertical axis to the orbit plane counter-clockwise, slowing the rotation, and then clockwise.

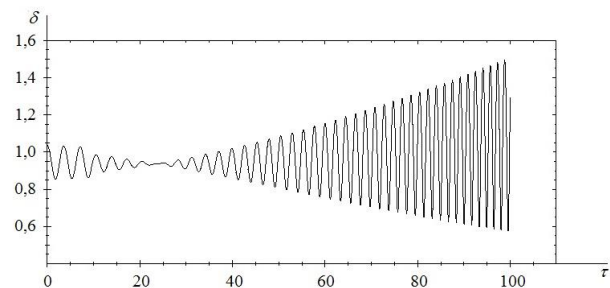

Fig. 1. Graph of changes in the angle of deviation of the vector  $\mathbf{G}$  from the vertical to the plane of the orbit

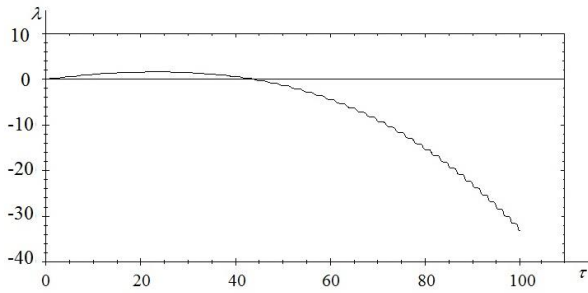

Fig. 2. Graph of changes in the angle of rotation of the vector  $\mathbf{G}$  around the vertical to the plane of the orbit

Fig. 3 shows the variation curves of the modulus of the kinetic momentum vector  $\tilde{G}(\tau)$  (Curve 1), the kinetic energy  $\tilde{T}(\tau)$  (Curve 2), and the modulus of the elliptic functions  $k^2(\tau)$  (Curve 3). All functions are decreasing, since under the influence of the moment of resistance forces the attenuation of the perturbed motion of the satellite relative to the centre of mass occurs.

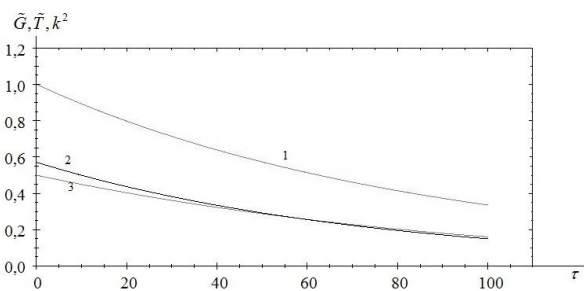

Fig. 3. Graphs of changes in kinetic energy, kinetic momentum and modulus of elliptic functions

Conduct the simulation of hodograph of the kinetic moment vector according to the performed numerical calculations. Fig. 4 shows the result using our own visualization package for a three-dimensional hodograph curve. The outer sphere of the frame type corresponds to the initial value of the modulus of the angular momentum vector, and the inner continuous sphere corresponds to the final calculated value of the modulus of the vector  $\mathbf{G}$ . The black curve is a three-dimensional hodograph that simulates the motion of a satellite relative to the centre of mass under the influence of the combined moments of light pressure and resistance for given parameters of the model.

From Fig.4 it can be seen that the hodograph of the kinetic moment vector  $\mathbf{G}$  covers the  $Ox_3$  axis.

The influence of the moment of the forces of light pressure is characterized by the dimensionless

parameter  $\chi_1$  (10), which is included in the right set of members of the first equations of the system (11). Changing this parameter affects changes in the functions  $\delta(\tau)$  and  $\lambda(\tau)$ . Fig. 5 shows the result of calculating the function of the deviation of the angular momentum vector from the vertical to the orbit plane. Curve 1 corresponds to the value of  $\chi_1 = 1$ , curve 2 -  $\chi_1 = 2$ , curve 3 -  $\chi_1 = 3$ . It can be seen that an increase in the parameter of the light pressure leads to an increase in the amplitude and a decrease in the oscillation period, but the nature of the function is preserved.

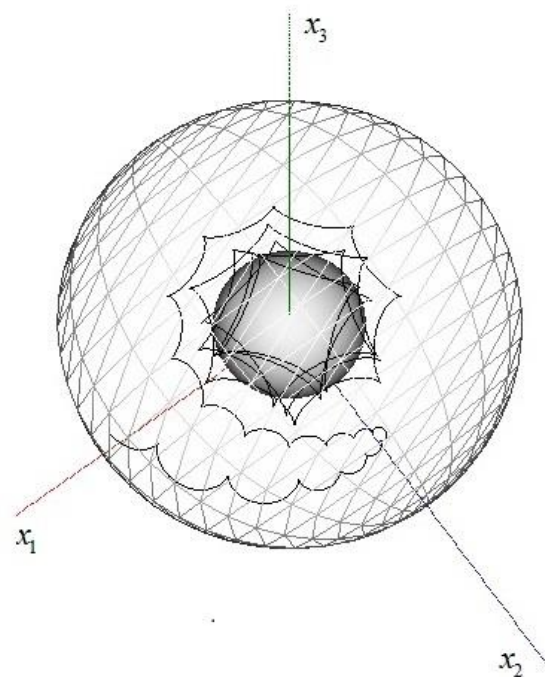

Fig. 4. Hodograph of the kinetic momentum vector

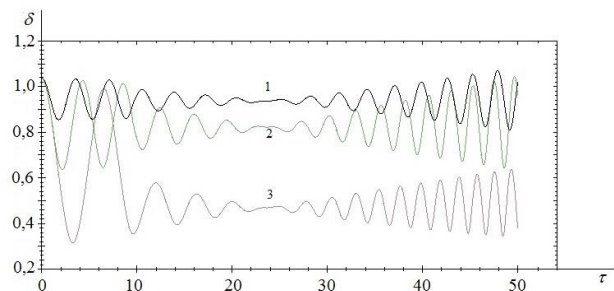

Fig. 5. The influence of the moment of force of light pressure on the angle of deviation

The magnitude of the modulus of the elliptic functions affects the gradients of the functions of the satellite's motion characteristics relative to the

centre of mass. Fig. 6 shows the curves of the angle of rotation  $\lambda$  for different values of the input parameter. Curve 1 corresponds to  $k^2 = 0.99$ , curve 2 - to  $k^2 = 0.5$ , curve 3 - to  $k^2 = 0.3$ . The hodograph of the kinetic moment vector has a character similar to that shown in Fig. 4.

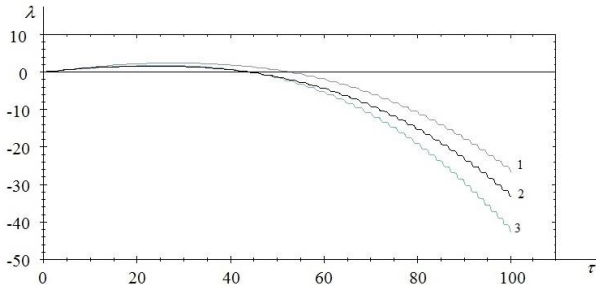

Fig. 6. The influence of the moment of force of light pressure on the angle of rotation

The study of satellite motion in an elliptical orbit for  $0 < e < 1$  showed that the hodograph of the angular momentum vector has minor changes.

The hodograph of the kinetic moment vector has a significant effect on the initial value of the orientation angle  $\delta$ .

Carry out a numerical calculation for the parameters  $e = 0, \tilde{A}_2 = 0.8, \tilde{A}_3 = 0.5, \nu_0 = 0, k^2 = 0.5, I_{11} = I_{22} = I_{33} = 0.01, \chi_1 = 1, \lambda_0 = 0$  for different initial values of the angle of deviation of the vector  $\mathbf{G}$  from the vertical axis to the plane of the orbit. Fig. 7 shows the result of modelling the hodograph of the kinetic moment vector for  $\delta_0 = 0.25\pi$ , in Fig. 8 – for  $\delta_0 = 0.5\pi$ .

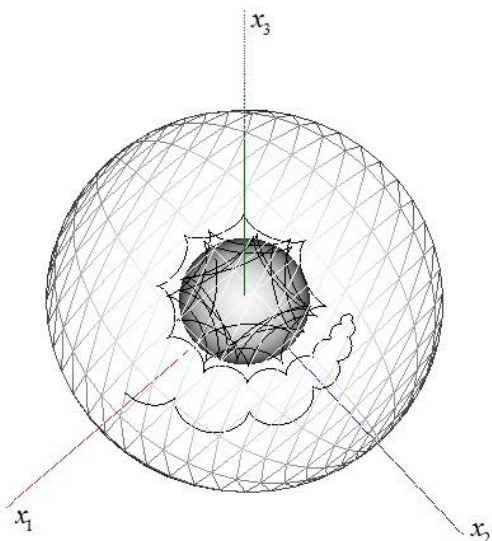

Fig. 7. Hodograph for  $\delta_0 = 0.25\pi$

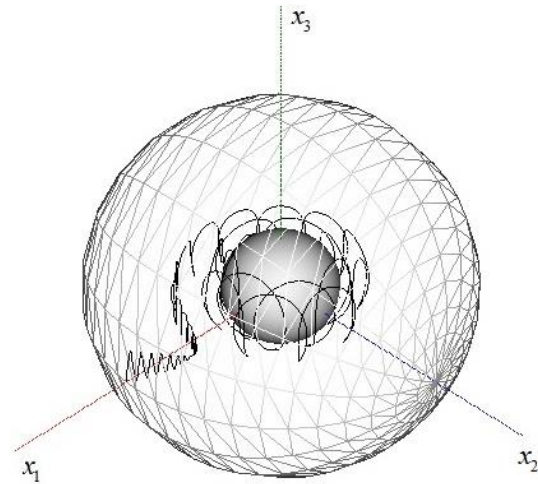

Fig. 8. Hodograph for  $\delta_0 = 0.5\pi$

According to the simulated hodographs of the kinetic moment vector of Fig. 4, Fig.7, Fig 8, it can be concluded that increasing the initial angle of deflection of the vector  $\mathbf{G}$  from the vertical to the orbital plane reduces the time of rotation of this vector near the vertical axis in the counterclockwise direction.

Changing the initial value of the angle of rotation of the vector  $\mathbf{G}$  does not change the character of the hodograph, but performs the rotation of the curve by the initial angle  $\lambda_0$ .

Conduct a study for a satellite with a different mass geometry, taking into account the fulfillment of the inequality  $1 > \tilde{A}_2 > \tilde{A}_3$  for which relation (5) is valid. Perform a numerical calculation for the parameters  $e = 0, \nu_0 = 0, k^2 = 0.5, I_{11} = I_{22} = I_{33} = 0.01, \chi = 1, \lambda_0 = 0, \delta_0 = 0.33\pi$ . Set the moments of inertia of the satellite  $\tilde{A}_2 = 0.2, \tilde{A}_3 = 0.1$ . These values correspond to the body which mass is more distributed along the  $Ox_1$  axis.

According to Fig. 9, the rotation of the kinetic moment vector occurs only in the clockwise direction, while the hodograph itself has a different form. The same direction of motion of the angular momentum vector will be maintained in the case of a satellite with a mass distributed along the two axes  $Ox_1$  and  $Ox_2$ . Fig. 10 shows the simulated hodograph of the kinetic moment vector for the geometry of masses  $\tilde{A}_2 = 0.9, \tilde{A}_3 = 0.1$ . It is seen

that an almost uniform mass distribution in the  $Ox_1x_2$  plane leads to a more sinusoidal hodograph curve.

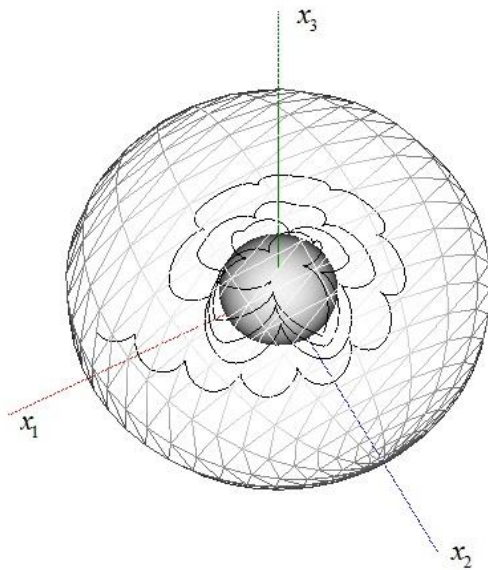

Fig. 9. Hodograph for a satellite with a mass distributed along the  $Ox_1$  axis

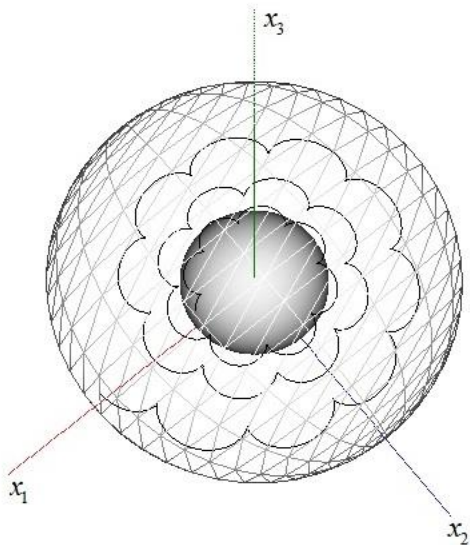

Fig. 10. Hodograph for a satellite with a mass distributed in the  $Ox_1x_2$  plane

To conduct numerical simulations of a satellite with  $1 < \tilde{A}_2 < \tilde{A}_3$  mass geometry, it is necessary to swap  $A_1$  and  $A_3$  in the equations of system (6) and equality (5). In addition, the value of  $\chi$  in equation (9) is replaced by  $-\chi$ , and in equation (9) add the minus sign (“-“). The conducted numerical analysis

did not reveal any new types of hodographs of the kinetic moment vector.

For a complete analysis of the constructed model, it is necessary to consider the moment of resistance forces for which  $I_{11} \neq I_{22} \neq I_{33}$ .

Perform a numerical calculation for the parameters  $e = 0, \tilde{A}_2 = 0.8, \tilde{A}_3 = 0.5, v_0 = 0, k^2 = 0.5, \chi_1 = 1, \lambda_0 = 0, \delta_0 = 0.33\pi$  provided that the moment of resistance force has a projection only on  $Ox_3$ . Fig. 11 shows the result of modelling the hodograph of the kinetic moment vector for  $I_{11} = I_{22} = 0, I_{33} = 0.1$ . It is seen from the figure that a feature of this hodograph is its rotation on a small value of the modulus of the vector of the kinetic moment.

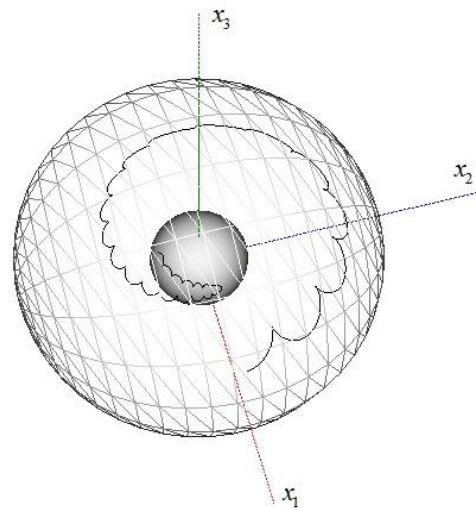

Fig.11 Effect of resistance on the hodograph.

A numerical analysis carried out for different values of the components of the inertia tensor showed that all possible hodographs of the kinetic moment vector in this satellite model have been modelled.

**Conclusions and prospects for further research.** A numerical study of the perturbed motion of the satellite under the influence of the combined effect of the moments of the forces of light pressure and resistance has been carried out. An analysis of the model obtained and the results showed that by modelling satellites with different mass geometries, we can obtain the rotation of the angular momentum relative to the centre of mass in different directions around the vertical axis to the orbit plane. The hodograph of the vector  $\mathbf{G}$  always covers the vertical axis to the orbit plane.



The analysis showed that the initial value of the deviation of the angular momentum vector from the vertical axis to the orbit plane has a significant effect on the hodograph form.

It makes sense to construct a similar model in the case of a quasi-rigid body with a cavity completely filled with a viscous fluid, to simulate a liquid satellite core.

### References

1. Beletskii, V. V. (1966). "Motion of an Artificial Satellite about Its Center of Mass", Washington, *NASA TT F Publ.*, 429 p. (translated from the Russian).
2. Karyimov, A. A. (1964). Ustoychivost vraschatelnogo dvizheniya geometricheski simmetrichnogo iskusstvennogo sputnika Solntsa v pole sil svetovogo davleniya. [Stability of rotational motion of a geometrically symmetric artificial satellite of the Sun in the field of light pressure forces], *Prikl. Math. Mekh.*, Vol. 28(5), pp. 923-930 (in Russian).
3. Chernousko, F. L. (1972). "The Movement of a Rigid Body with Cavities Containing a Viscous Fluid", Washington, *NASA Publ.*, 214 p. (translated from the Russian).
4. Akulenko, L. D., Leschenko, D. D., & Chernousko, F. L. (1982). Byistroe dvizhenie vokrug nepodvijnoy tochki tyazhelogo tverdogo tela v soprotivlyayusheysya srede. [Fast motion of a heavy rigid body about a fixed point in a resistive medium], *Mech. Solids*, Vol. 17(3), pp. 1-8 (translated from the Russian).
5. Sazonov, V. V. (1994). Dvizhenie asteroida otnositelno tsentra mass pod deystviem momenta sil svetovogo davleniya. [Motion of an asteroid relative to the centre of mass under the action of the moment of light pressure forces], *Astr. Vestnik.*, Vol. 28(2), pp. 95-107 (in Russian).
6. Sidorenko, V. V. (1994). "Capture and escape from resonance in the dynamics of the rigid body in viscous medium", *J. Nonlinear Sci.*, Vol.4, pp. 35-57.
7. Leschenko, D. D., & Rachinskaya, A. L. (2007). Dvizhenie sputnika otnositelno tsentra mass pod deystviem momenta sil svetovogo davleniya v soprotivlyayusheysya srede. [The motion of the satellite relative to the center of mass under the action of the moment of the forces of light pressure in a resisting medium], *Bulletin of the Odessa National University*, Vol.12 (7), pp. 85-98 (in Russian).
8. Akulenko, L. D., Leschenko, D. D., Rachinskaya, A. L., & Zinkevich, Ya. S. (2013). Vozmuschennyie i upravlyaemyie dvizheniya tverdogo tela: monografiya. [Perturbed and controlled motions of a rigid body: monograph], Odessa, Ukraine, *Odessa National University. I. I. Mechnikov Publ.*, 288 p., ISBN 978-617-698-045-4 (in Russian).
9. Chernousko, F. L., Akulenko, L. D., & Leschenko, D. D. (2015). Evolyutsiya dvizheniy tverdogo tela otnositelno tsentra mass: monografiya. [The evolution of rigid body motions relative to the center of mass: monograph], Moscow-Izhevsk, Russian Federation, *Izhevsk Institute of Computer Research Publ.*, 308 p. ISBN 978-5-4344-294-1 (in Russian).
10. Chernousko, F. L., Akulenko, L. D., & Leschenko, D. D. (2017), "Evolution of Motions of a Rigid Body About its Center of Mass", *Cham, Springer International Publishing AG Publ.*, 248 p. DOI 10.1007/978-3-319-53928-7.
11. Rachinskaya, A. L., & Rumyantseva, E. A. (2018). "Optimal deceleration of a rotating asymmetrical body in a resisting medium", *International Applied Mechanics*, Vol. 54(6), pp. 710-717. DOI 10.1007/s10778-018-0926-7.
12. Raus, E. Dj. (1983). Dinamika sistemyi tverdyyih tel. T.II. [System dynamics of solids], Moscow, Russian Federation, *Nauka Publ.*, 463 p.
13. Polyahova, E. N. (2011). Kosmicheskiy polet s solnechnym parusom. [Space Flight with a Solar Sail], Moscow, Russian Federation, *Librokom Book House Publ.*, 320 p. (in Russian).
14. Modi, V. J. (1995). "On the semi-passive attitude control and propulsion of space vehicles using solar radiation pressure", *Acta Astronautica*, Vol. 35(2-3), pp. 231-246.
15. Vokrouhlicky, D., & Milani, A. (2000). "Direct solar radiation pressure on the orbits of small near-earth asteroids: observable effects", *Astr. Astrophys.*, Vol. 362, pp. 746-755.
16. Rubincam, D. P. (2000). "Radiative spin-up and spin-down of small asteroids". *ICARUS*, Vol. 148, pp. 2-11.
17. Gurchenkov, A. A., Nosov, M. V., & Tsurkov, V. I. (2013). "Control of Fluid Containing Rotating Rigid Bodies", New York : *CRC Press Publ.*, 160 p.
18. Robinson, J. C., Rodrigo, J. L., Sadowski W., & Vidal-López A. (2016). "On the motion of a pendulum with a cavity entirely filled with a viscous liquid", *Cambridge University Press Publ.*, pp. 37-56, ISBN 9781316407103.
19. Ramodanov, S. M., & Sidorenko, V. V. (2017). "Dynamics of a rigid body with an ellipsoidal cavity filled with viscous fluid", *International*

*Journal of Non-Linear Mechanics*, Vol. 95, pp. 42-46. DOI: 10.1016.

20. Kutsenko, L., Semkiv, O., & Zapolskiy, L. Geometricheskoe modelirovanie vrascheniya tverdogo tela v modeli Puanso i obyasnienie effekta Djanibekova. [Geometrical modeling of rotation solid state in the model of poinso and explanation of the Janibekov effect], *Geometric model and information technology*, Vol. 2(4), pp. 41-50. ISSN 2524-0978 (in Russian).

21. Verlan, A. F., Polojaenko, S. A., Prokofeva, L. L., & Shilov, V. P. (2018), Diagnostirovanie podsystem, harakterizuyuschih svoystvami nezavisimogo nablyudeniya i upravleniya. [Diagnosis of substances, which characterize the properties of independent observation and control], *Applied Aspects of Information Technology*, Vol. 1, No.1, pp. 33-47 (in Russian).

22. Landau, L. D., & Lifshits, E. M., (1973). Teoreticheskaya fizika. T. 1, Mehanika. [Theoretical physics. T. 1, Mechanics], Moscow, Russian Federation, *Nauka Publ.*, 208 p. (in Russian).

23. Gradshteyn, I. S., & Ryjik, I. M., (1971). Tablitsyi integralov, summ, ryadov i proizvedeniy. [Tables of integrals, sums, series and products], Moscow, Russian Federation, *Nauka Publ.*, 1108 p. (in Russian).

24. Volosov, V. M., & Morgunov B. I. (1971). Metod osredneniya v teorii nelineynykh kolebatelnykh sistem. [The averaging method in the theory of nonlinear oscillatory systems], Moscow, Russian Federation, *MGU Publ.*, 507 p. (in Russian).

Received 17.12.2018

<sup>1</sup>**Рачинська, Алла Леонідівна**, кандидат фізико-математичних наук, доцент, доцент кафедри теоретичної механіки, E-mail: rachinskaya@onu.edu.ua

<sup>1</sup>Одеський національний університет імені І. І. Мечникова, вул. Дворянська, 2, Одеса, Україна, 65082

### МОДЕЛЮВАННЯ РУХУ ТВЕРДОГО ТІЛА ПІД ДІЄЮ МОМЕНТУ СВІТОВОГО ТИСКУ В СЕРЕДОВИЩІ З ОПОРОМ

**Анотація.** Моделюється швидкий обертальний рух динамічно несиметричного супутника відносно центру мас під дією спільного впливу моменту сил світлового тиску і опору. Передбачається, що поверхня космічного апарату представляє собою поверхню обертання. Середовище створює слабкий опір пропорційний кутовій швидкості власного обертання тіла відносно центру мас. Орбітальні рухи з довільним ексцентриситетом вважаються заданими. Математична модель руху супутника в такій постановці описується жорсткою системою диференціальних рівнянь. Проводиться усереднення за рухом Ейлера-Пуансо. Усереднена система рівнянь руху тіла дозволяє проводити чисельне моделювання руху супутника відносно центру мас. Дослідження проводиться в безрозмірному вигляді для багатопараметричної системи рівнянь. Проведено аналіз впливу параметрів завдання на характер руху супутника відносно центру мас: початкових значень кутів орієнтації вектора кінетичного моменту, геометрії мас, ексцентриситету орбіти, характерних чисел збурюючих моментів. Моделюється годограф вектора кінетичного моменту у тривимірному просторі для різних значень параметрів системи.

**Ключові слова:** геометрія мас, годограф; кінетичний момент; світловий тиск; опір; супутник

<sup>1</sup>**Рачинская, Алла Леонидовна**, кандидат физико-математических наук, доцент, доцент каф. теоретической механики, E-mail: rachinskaya@onu.edu.ua

<sup>1</sup>Одесский национальный университет имени И. И. Мечникова, ул. Дворянская, 2, Одесса, Украина, 65082

### МОДЕЛИРОВАНИЕ ДВИЖЕНИЯ ТВЕРДОГО ТЕЛА ПОД ДЕЙСТВИЕМ МОМЕНТА СВЕТОВОГО ДАВЛЕНИЯ В СРЕДЕ С СОПРОТИВЛЕНИЕМ

**Аннотация.** Моделируется быстрое вращательное движение динамически несимметричного спутника относительно центра масс под действием совместного влияния момента сил светового давления и сопротивления. Предполагается, что

поверхность космического аппарата представляет собой поверхность вращения. Среда создает слабое сопротивление пропорциональное угловой скорости собственного вращения тела относительно центра масс. Орбитальные движения с произвольным эксцентриситетом считаются заданными. Математическая модель движения спутника в такой постановке описывается жесткой системой дифференциальных уравнений. Проводится усреднение по движению Эйлера–Пуансо. Усредненная система уравнений движения тела позволяет проводить численное моделирование движения спутника относительно центра масс. Исследование проводится в безразмерном виде для многопараметрической системы уравнений. Проведен анализ влияния параметров задачи на характер движения спутника относительно центра масс: начальных значений углов ориентации вектора кинетического момента, геометрии масс, эксцентриситета орбиты, характерных чисел возмущающих моментов. Моделируется годограф вектора кинетического момента в трехмерном пространстве при различных значениях параметров системы.

**Ключевые слова:** геометрия масс; годограф; кинетический момент; световое давление; сопротивление; спутник